

The logo features a black inverted triangle with a red circle at its base, positioned to the left of the word "Doofor" in a large, bold, black sans-serif font. Below "Doofor", the words "ROCK DRILLS" are written in a smaller, red, all-caps sans-serif font.

Doofor
ROCK DRILLS



THE ROCK DRILL COMPANY.

DOOFOR INC. THE COMPANY

Doofor Inc. designs and manufactures hydraulic rock drills for drilling equipment manufacturers and rebuilders around the world.

Doofor offers drilling technology of the highest quality to ensure the overall functionality and successful operation of hydraulic drilling equipment. The rock drill is a key component when building successful hydraulic top-hammer rock drilling equipment.

Our unique rock drills are designed to endure the most demanding environments and maintain superior performance in extreme working conditions. As a pioneer in the drilling industry, we have successfully integrated valuable industry knowhow into our products to combine drilling speed, energy efficiency and durability.

Enhance your drilling equipment with Doofor Rock Drills

Doofor has been in the industry since 1993. This means that the needs of original drilling equipment manufacturers are our top priority. We strive for long term partnerships in building competitive drilling equipment together with our clients.

Our highly skilled workforce and subcontracting network ensures good lead times and flexibility.

Doofor works closely with customers and end-users in finding the most durable and economical solutions.

Doofor offers original spare parts availability, maintenance and service training, fast deliveries, as well as ongoing technical and commercial support.

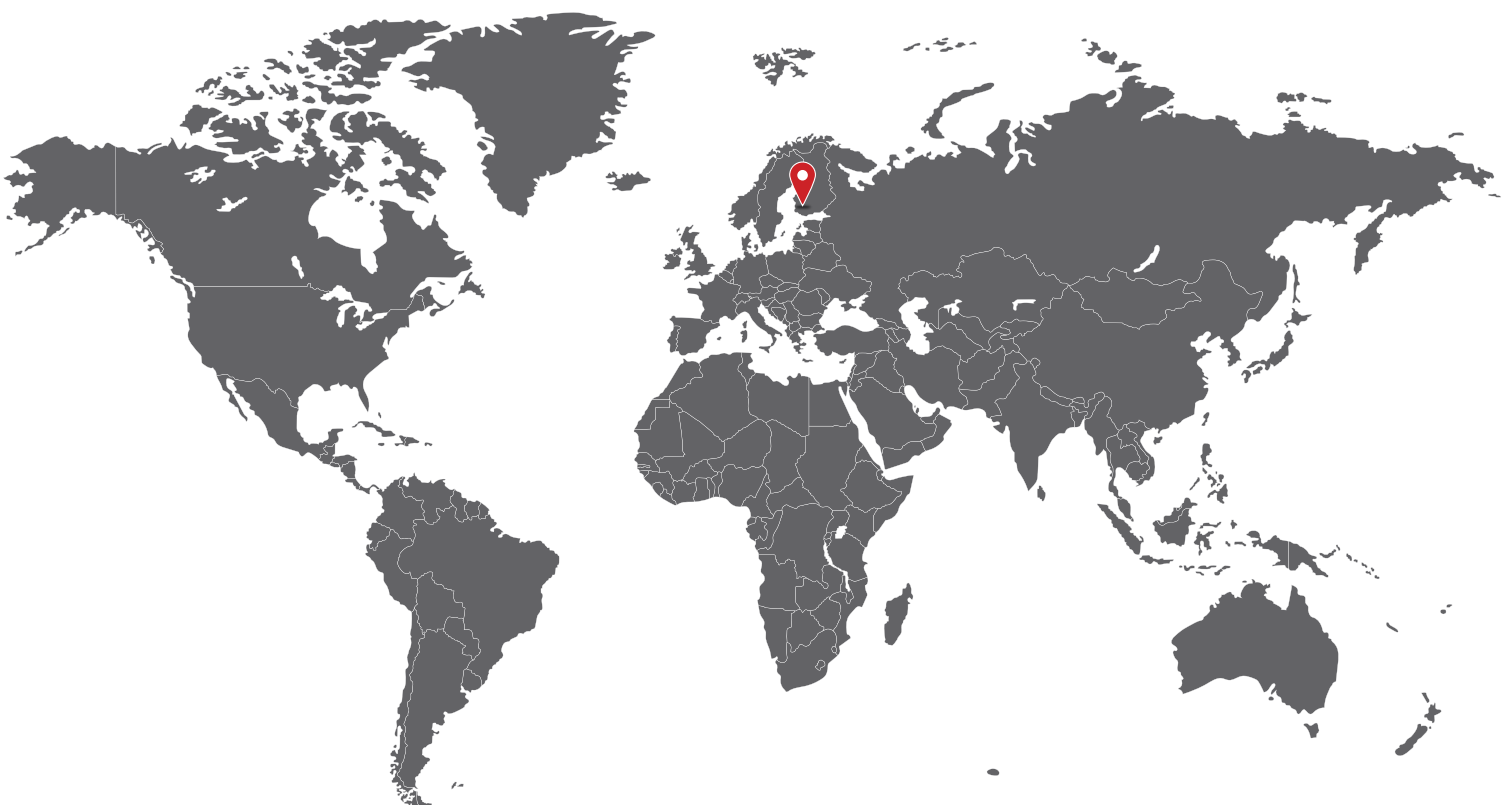

Trustable production in modern facilities

Our purpose-built premises in Nokia, Finland, and lean production methods ensure timely delivery of necessary components. Our manufacturing is ISO9001:2015 certified and all products are test run before delivery to guarantee their functions. Doofor uses components from selected high quality sub-contractors and material suppliers. We only use the highest quality steel, bronze and other materials in our production.

Competitive Doofor rock drills use the latest technology and components of the highest quality which offer multiple benefits.

- Minimal drill hole deviation
- Good drill tool and spare part economy
- Effortless service and repairs
- Speedy penetration
- Excellent energy efficiency

Doofor high-performance hydraulic rock drills are compact and robust, and they can be installed in most types of hydraulic drilling platforms. Doofor rock drills are used in multitude of demanding jobs, such as rock excavations, soil nailing, grouting, aggregate quarrying, tunnelling, bolting, anchoring, dimensional stone drilling, probe drilling, underground bolting and anchoring and many others.

In addition to rock drills, Doofor offers aluminium profiles and hydraulic feed system component kits for machine building professionals. Doofor also offers a variety of precision-built carriage plates for the rock drills.

Family owned dedication.

Doofor is an independent and privately owned family business that values customer service and long-term commitment. Our goal is to make our customers successful by providing the latest drilling technology and allowing them to focus on other important aspects of hydraulic drilling equipment design and manufacture. **We succeed when our customers succeed.**



**THE
ROCK
DRILL
COMPANY.**

DF430X HIGH-PERFORMANCE HYDRAULIC ROCK DRILL



Doofor DF430X is a lightweight, high-frequency hydraulic rock drill designed for use in general excavations, quarrying and bolting operations. Flushing media can be air or water. This rock drill has a female hexagonal chuck. Simple design allows for easy serviceability.

This model can be used with a Doofor original drill feed system component kit.

CIVIL ENGINEERING AND SURFACE

TECHNICAL SPECIFICATIONS

DOOFOR DF430X DRIFTER

NOMINAL POWER CLASS		5 kW	6.7 hp
DRILL HOLE SIZE ⁴⁾		41 mm	1 3/5"
PERCUSSION FLOW		45 l/min	12 gpm
PERCUSSION PRESSURE		120 bar	1740 psi
ROTATION MOTOR MAXIMUM FLOW ¹⁾	12.5cc	25 l/min	6.6 gpm
	20cc	25 l/min	6.6 gpm
	32cc	25 l/min	6.6 gpm
	40cc	25 l/min	6.6 gpm
ROTATION TORQUE ¹⁾	12.5cc	64 Nm	47 lb-ft
	20cc	97 Nm	71 lb-ft
	32cc	158 Nm	116 lb-ft
	40cc	194 Nm	143 lb-ft
ROTATION PRESSURE MAXIMUM ⁵⁾		140 bar	2031 psi
ROTATION SPEED MAXIMUM ²⁾	12.5cc	560 rpm	
	20cc	361 rpm	
	32cc	227 rpm	
	40cc	180 rpm	
LUBRICATION	Air-oil mist	125-200 g/h	4.9-78 fl oz/h (1.4-2.3 dl/h)
LUBRICATION PRESSURE		4-7 bar	58-101 psi
LUBRICATION AIR FLOW		200-300 l/min	53-79 gpm
FLUSHING AIR PRESSURE ³⁾		5-8 bar	73-116 psi
FLUSHING AIR FLOW ³⁾		700-1200 l/min	185-317 gpm
FLUSHING WATER PRESSURE ³⁾		4-12 bar	58-174 psi
FLUSHING WATER FLOW ³⁾		15-30 l/min	4-8 gpm
RECOMMENDED MAXIMUM FEED FORCE		3.7 kN	830 lbf
WEIGHT		41 kg	90 lb
SHANK SIZE		108mm [4 1/4"] * 22mm [7/8"] or 25mm [1"]	

¹⁾ Intermittent maximum value. Rotation flow is typically lower during normal operation.

²⁾ Continuous value. Maximum recommended speed 300 rpm.

³⁾ Actual values vary according to drilling conditions and equipment.

⁴⁾ Maximum drill hole size in normal drilling applications.

⁵⁾ Confirm the maximum pressure drop from the manual or the motor specifications.

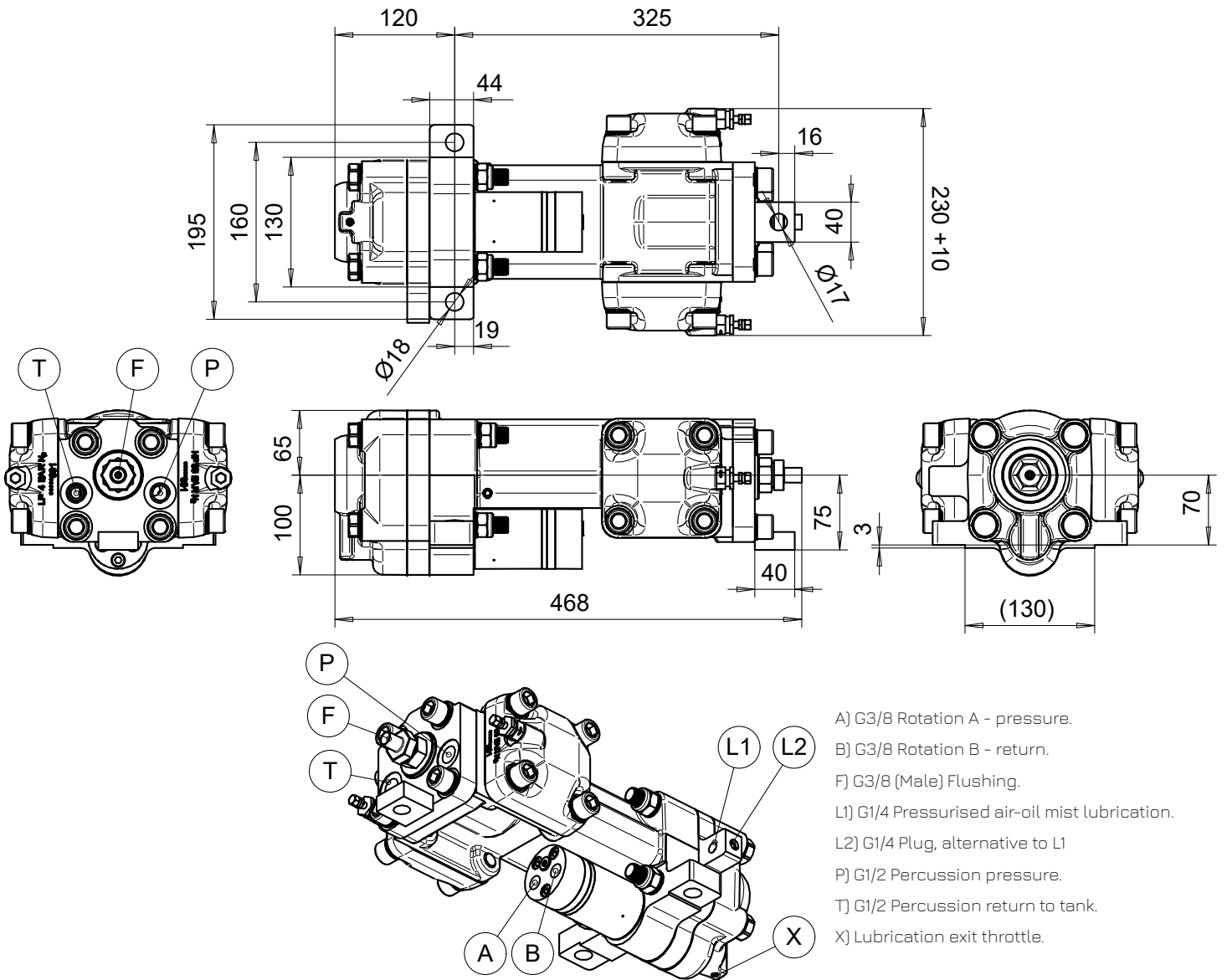

Doofor DF430X has alternative models: Doofor DF430S with a male shank adapter and light piston models Doofor DF420X and Doofor DF410X.



DF430S

HIGH-PERFORMANCE HYDRAULIC ROCK DRILL

Doofer DF430S is lightweight, high-frequency rock drills designed for use in general excavations, quarrying and bolting.

DF430S uses R25 or R28 male shank adapter with air or water flushing. The rock drill is equipped with a separate flushing box. Doofer DF430S is easy to maintain due to compact, modular design.

DF430S can be used with a Doofer original drill feed system component kit.



CIVIL ENGINEERING, UNDERGROUND AND SURFACE

TECHNICAL SPECIFICATIONS

DOOFER DF430S DRIFTER

NOMINAL POWER CLASS		5 kW	6.7 hp
DRILL HOLE SIZE ⁴⁾		41 mm	1 3/5"
PERCUSSION FLOW		45 l/min	12 gpm
PERCUSSION PRESSURE		120 bar	1740 psi
ROTATION MOTOR MAXIMUM FLOW ¹⁾	12.5cc	25 l/min	6.6 gpm
	20cc	25 l/min	6.6 gpm
	32cc	25 l/min	6.6 gpm
	40cc	25 l/min	6.6 gpm
ROTATION TORQUE ¹⁾	12.5cc	64 Nm	47 lb-ft
	20cc	97 Nm	71 lb-ft
	32cc	158 Nm	116 lb-ft
	40cc	194 Nm	143 lb-ft
ROTATION PRESSURE MAXIMUM ⁵⁾		140 bar	2031 psi
ROTATION SPEED MAXIMUM ²⁾	12.5cc	560 rpm	
	20cc	361 rpm	
	32cc	227 rpm	
	40cc	180 rpm	
LUBRICATION	Air-oil mist	125-200 g/h	4.9-7.8 fl oz/h (1.4-2.3 dl/h)
LUBRICATION PRESSURE		4-7 bar	58-101 psi
LUBRICATION AIR FLOW		200-300 l/min	53-79 gpm
FLUSHING AIR PRESSURE ³⁾		5-8 bar	73-116 psi
FLUSHING AIR FLOW ³⁾		700-1200 l/min	185-317 gpm
FLUSHING WATER PRESSURE ³⁾		4-12 bar	58-174 psi
FLUSHING WATER FLOW ³⁾		15-30 l/min	4-8 gpm
RECOMMENDED MAXIMUM FEED FORCE		8 kN	1798 lbf
WEIGHT		50 kg	110 lb
SHANK SIZE		Male R25, R28	

¹⁾ Intermittent maximum value. Rotation flow is typically lower during normal operation.

²⁾ Continuous value. Maximum recommended speed 300 rpm.

³⁾ Actual values vary according to drilling conditions and equipment.

⁴⁾ Maximum drill hole size in normal drilling applications.

⁵⁾ Confirm the maximum pressure drop from the manual or the motor specifications.

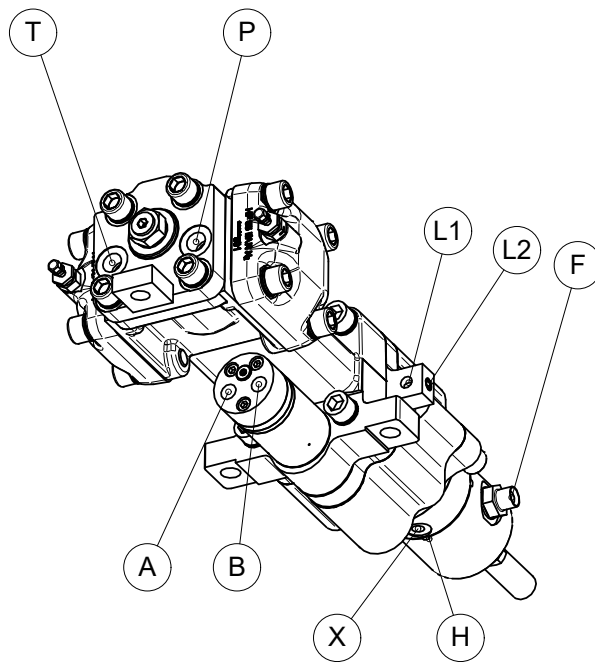
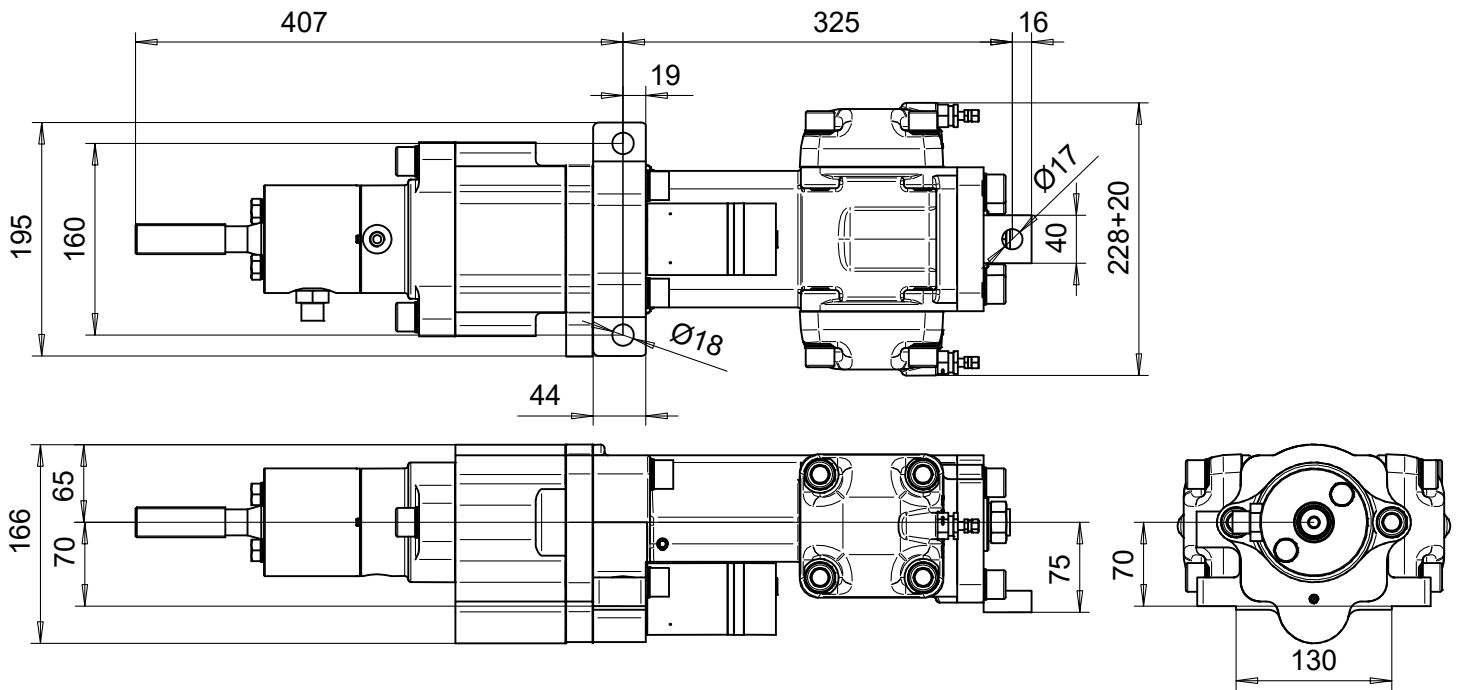

- A) G3/8 Rotation A.
- B) G3/8 Rotation B.
- F) G1/2 Flushing.
- H) Flushing seal leak indicator hole.
- L1) G1/4 Pressurised air-oil mist lubrication.
- L2) G1/4 Plug, alternative to L1
- P) G1/2 Percussion pressure.
- T) G1/2 Percussion return to tank.
- X) G1/4 Lubrication exit.



DFR2 HIGH-PERFORMANCE HYDRAULIC ROCK DRILL

Doofor DFR2 is a new generation high-power, high-frequency rock drill used for general excavations and quarrying. This rock drill is equipped with a hexagonal female chuck. Flushing media can be air or water. The rock drill has a thorough-piston flushing tube and advanced piston sealing.

DFR2 uses a high-energy piston shape for high-penetration speed in hard rock drilling operations and is efficient in preserving good drill tool life.

This model can be used with a Doofor original drill feed system component kit.

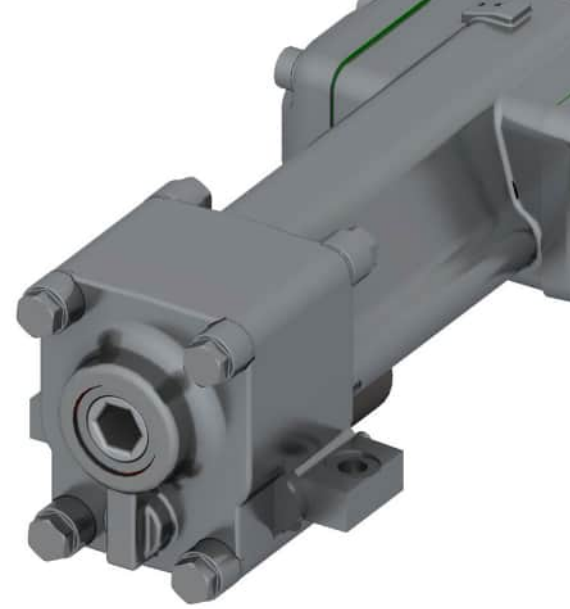

**CIVIL ENGINEERING, DIMENSIONAL,
SURFACE AND UNDERGROUND**

TECHNICAL SPECIFICATIONS

DOOFOR DFR2 DRIFTER

NOMINAL POWER CLASS		7 kW	9.4 hp
DRILL HOLE SIZE ⁴⁾		45 mm	1 3/4"
PERCUSSION FLOW		40–50 l/min	10.5–13.2 gpm
PERCUSSION PRESSURE		130–160 bar	1885–2321 psi
ROTATION MOTOR MAXIMUM FLOW ¹⁾	12.5cc	25 l/min	6.6 gpm
	20cc	25 l/min	6.6 gpm
	32cc	25 l/min	6.6 gpm
	40cc	25 l/min	6.6 gpm
	50cc	25 l/min	6.6 gpm
ROTATION TORQUE ¹⁾	12.5cc	70 Nm	52 lb-ft
	20cc	107 Nm	79 lb-ft
	32cc	174 Nm	130 lb-ft
	40cc	214 Nm	158 lb-ft
	50cc	269 Nm	198 lb-ft
ROTATION PRESSURE MAXIMUM ⁵⁾		140 bar	2031 psi
ROTATION SPEED MAXIMUM ²⁾	12.5cc	506 rpm	
	20cc	326 rpm	
	32cc	205 rpm	
	40cc	163 rpm	
	50cc	130 rpm	
LUBRICATION	Air-oil mist	125–200 g/h	4.9–7.8 fl oz/h (1.4–2.3 dl/h)
LUBRICATION PRESSURE		7–12 bar	102–174 psi
LUBRICATION AIR FLOW		200–300 l/min	53–79 gpm
FLUSHING AIR PRESSURE ³⁾		5–12 bar	73–174 psi
FLUSHING AIR FLOW ³⁾		700–1200 l/min	185–317 gpm
FLUSHING WATER PRESSURE, MAX ³⁾		5 bar	73 psi
FLUSHING WATER FLOW ³⁾		25–40 l/min	6.6–10.6 gpm
RECOMMENDED MAXIMUM FEED FORCE		6 kN	1348 lbf
WEIGHT		61 kg	132 lb
CHUCK SIZE		108mm [4 1/4"] * 22mm [7/8"] or 25mm[1"]	

¹⁾ Intermittent value.

²⁾ Continuous value. Maximum recommended speed 300 rpm.

³⁾ Actual values vary according to drilling conditions and equipment.

⁴⁾ Maximum drill hole size in normal drilling applications.

⁵⁾ Confirm the maximum pressure drop from the manual or the motor specifications.

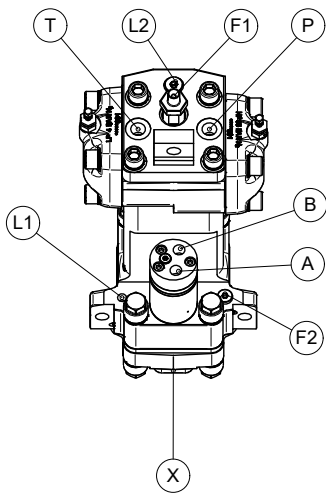
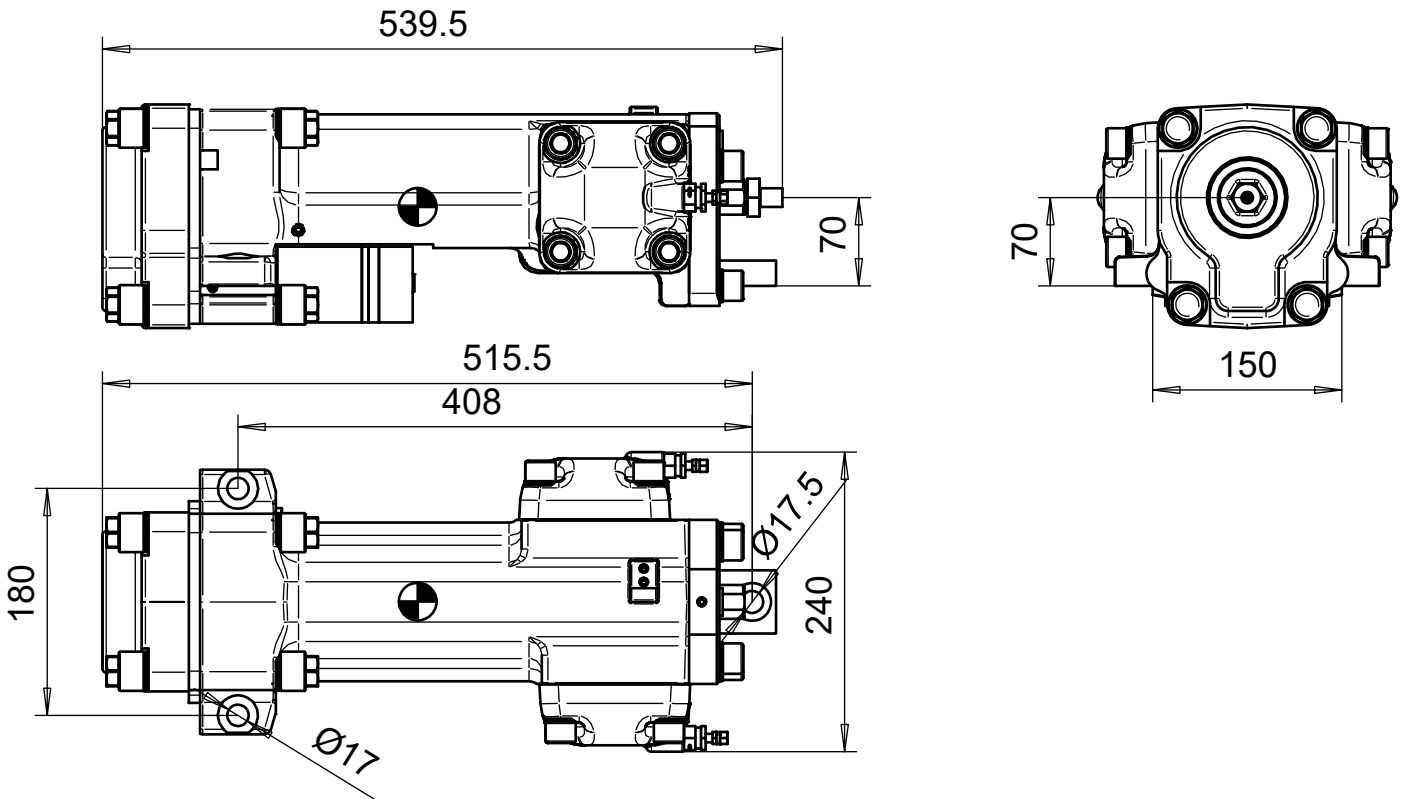

- A1) G3/8" Rotation A.
- B) G3/8" Rotation B.
- F1) G3/8" Male, Flushing.
- F2) Plug.
- L1) G1/4" Pressurised air-oil mist lubrication input.
- L2) G3/8" Additional air-oil mist lubrication input. Used only when suggested by the manufacturer.
- P) G1/2" Percussion pressure.
- T) G1/2" Percussion return to tank
- X) Throttled air-oil mist lubrication exit. Do not plug.

DF530X HIGH-PERFORMANCE HYDRAULIC ROCK DRILL

Doofer DF530X is a new generation high-power, high-frequency rock drill used for general excavations and quarrying. This rock drill is equipped with a hexagonal female chuck. Flushing media can be air or water.

DF530X uses a high-energy piston shape for high-penetration speed in hard rock drilling operations and is efficient in preserving good drill tool life.

This model can be used with a Doofer original drill feed system component kit.

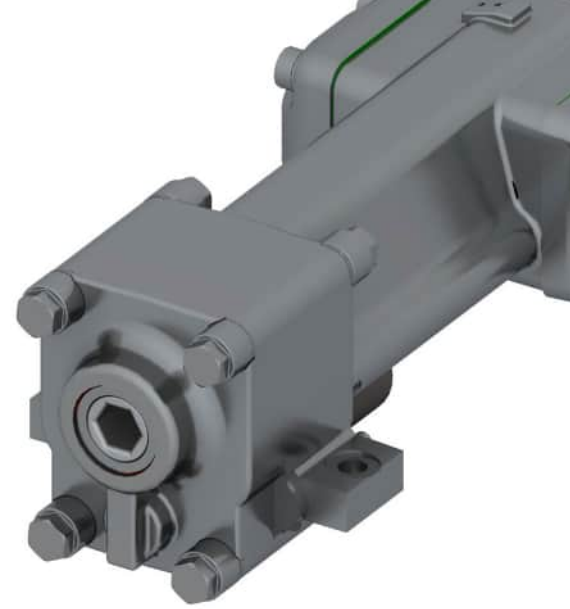

**CIVIL ENGINEERING, DIMENSIONAL,
SURFACE AND UNDERGROUND**

TECHNICAL SPECIFICATIONS

DOOFOR DF530X DRIFTER

NOMINAL POWER CLASS		10 kW	13.4 hp
DRILL HOLE SIZE ⁴⁾		45 mm	1 3/4"
PERCUSSION FLOW		45–55 l/min	11.9–14.5 gpm
PERCUSSION PRESSURE		100–130 bar	1450–1885 psi
ROTATION MOTOR MAXIMUM FLOW ¹⁾	12.5cc	25 l/min	6.6 gpm
	20cc	25 l/min	6.6 gpm
	32cc	25 l/min	6.6 gpm
	40cc	25 l/min	6.6 gpm
	50cc	25 l/min	6.6 gpm
ROTATION TORQUE ¹⁾	12.5cc	70 Nm	52 lb-ft
	20cc	107 Nm	79 lb-ft
	32cc	177 Nm	131 lb-ft
	40cc	214 Nm	158 lb-ft
	50cc	269 Nm	198 lb-ft
ROTATION PRESSURE MAXIMUM ⁵⁾		140 bar	2031 psi
ROTATION SPEED MAXIMUM ²⁾	12.5cc	506 rpm	
	20cc	326 rpm	
	32cc	205 rpm	
	40cc	163 rpm	
	50cc	130 rpm	
LUBRICATION	Air-oil mist	125–200 g/h	4.9–7.8 fl oz/h (1.4–2.3 dl/h)
LUBRICATION PRESSURE		4–7 bar	58–101 psi
LUBRICATION AIR FLOW		200–300 l/min	53–79 gpm
FLUSHING AIR PRESSURE ³⁾		5–12 bar	73–174 psi
FLUSHING AIR FLOW ³⁾		700–1200 l/min	185–317 gpm
FLUSHING WATER PRESSURE ³⁾		5–12 bar	73–174 psi
FLUSHING WATER FLOW ³⁾		25–40 l/min	6.6–10.6 gpm
RECOMMENDED MAXIMUM FEED FORCE		6 kN	1348 lbf
WEIGHT		55 kg	121 lb
SHANK SIZE		108mm [4 1/4"] * 22mm [7/8"] or 25mm[1"]	

¹⁾ Intermittent value.

²⁾ Continuous value. Maximum recommended speed 300 rpm.

³⁾ Actual values vary according to drilling conditions and equipment.

⁴⁾ Maximum drill hole size in normal drilling applications.

⁵⁾ Confirm the maximum pressure drop from the manual or the motor specifications.

DIMENSIONS

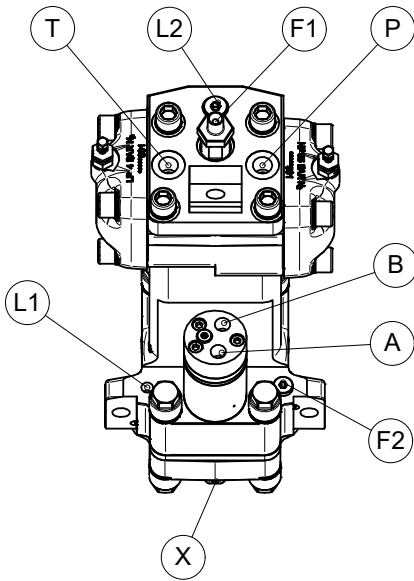
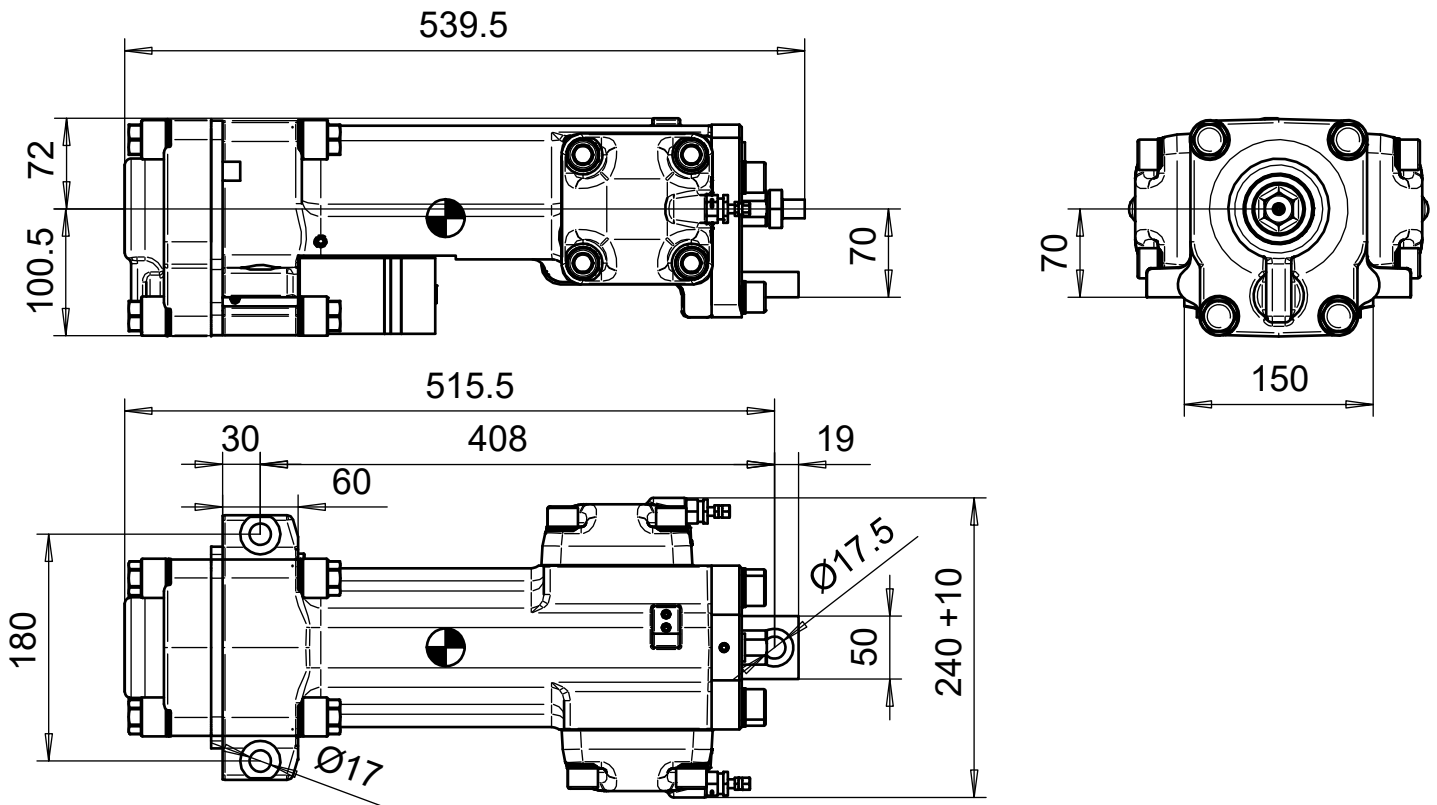

- A) G3/8 Rotation A.
- B) G3/8 Rotation B.
- F1) G3/8 (male) Flushing.
- F2) G1/4 Plug.
- L1) G1/4 Pressurised air-oil mist lubrication.
- L2) G3/8 Plug.
- P) G1/2 Percussion pressure.
- T) G1/2 Percussion return to tank.
- X) Lubrication exit throttle.

Alternative models for Doofor DF530X include Doofor DF530S with male shank adapter and Doofor DF530L with two side rotation motors for extra torque. New model DF530XS combines male or female shank adapters with short overall length.



DF530S HIGH-PERFORMANCE HYDRAULIC ROCK DRILL

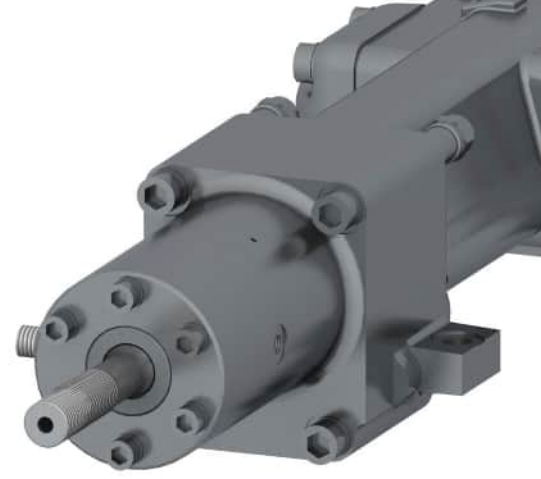

**CIVIL ENGINEERING,
SURFACE AND UNDERGROUND**

Doofor DF530S is a new generation, high-power, high-frequency rock drill used for general excavations, mining, and quarrying. This rock drill is equipped with a separated flushing box with side connection. Flushing is possible with water or air.

DF530S offers a long service life due to its simple, modular construction which makes maintenance easy and affordable.

This model can be used with a Doofor original drill feed system component kit.

TECHNICAL SPECIFICATIONS

DOOFOR DF530S DRIFTER

NOMINAL POWER CLASS		10 kW	13.4 hp
DRILL HOLE SIZE ⁴⁾		45 mm	1 3/4"
PERCUSSION FLOW		45–55 l/min	11.9–14.5 gpm
PERCUSSION PRESSURE		100–130 bar	1450–1885 psi
ROTATION MOTOR MAXIMUM FLOW ¹⁾	12.5cc	25 l/min	6.6 gpm
	20cc	25 l/min	6.6 gpm
	32cc	25 l/min	6.6 gpm
	40cc	25 l/min	6.6 gpm
	50cc	25 l/min	6.6 gpm
ROTATION TORQUE ¹⁾	12.5cc	70 Nm	52 lb-ft
	20cc	107 Nm	79 lb-ft
	32cc	177 Nm	131 lb-ft
	40cc	214 Nm	158 lb-ft
	50cc	269 Nm	198 lb-ft
ROTATION PRESSURE MAXIMUM ⁵⁾		140 bar	2031 psi
ROTATION SPEED MAXIMUM ²⁾	12.5cc	506 rpm	
	20cc	326 rpm	
	32cc	205 rpm	
	40cc	163 rpm	
	50cc	130 rpm	
LUBRICATION	Air-oil mist	125–200 g/h	4.9–78 fl oz/h (1.4–2.3 dl/h)
LUBRICATION PRESSURE		4–7 bar	58–101 psi
LUBRICATION AIR FLOW		200–300 l/min	53–79 gpm
FLUSHING AIR PRESSURE ³⁾		5–12 bar	73–174 psi
FLUSHING AIR FLOW ³⁾		700–1200 l/min	185–317 gpm
FLUSHING WATER PRESSURE ³⁾		5–12 bar	73–174 psi
FLUSHING WATER FLOW ³⁾		25–40 l/min	6.6–10.6 gpm
RECOMMENDED MAXIMUM FEED FORCE		12.5 kN	2810 lbf
WEIGHT		77 kg	170 lb
SHANK SIZE		Male R28, R32	

¹⁾ Intermittent value.

²⁾ Continuous value. Maximum recommended speed 300 rpm.

³⁾ Actual values vary according to drilling conditions and equipment.

⁴⁾ Maximum drill hole size in normal drilling applications.

⁵⁾ Confirm the maximum pressure drop from the manual or the motor specifications.

DIMENSIONS

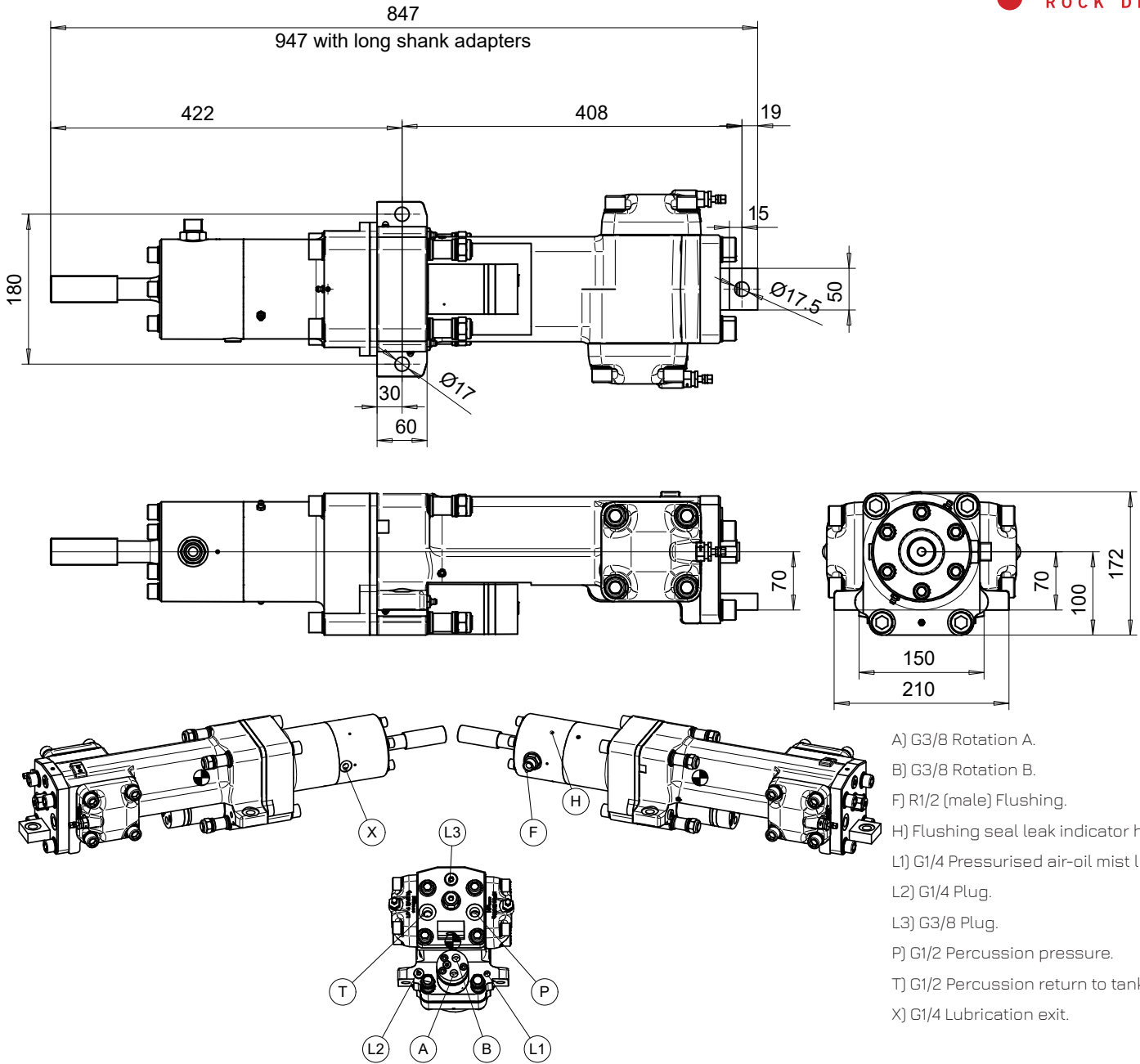

Alternative models for Doofor DF530S include Doofor DF530X with hexagonal chuck and Doofor DF530L with two side rotation motors for extra torque.



DOOFOR DF530L HIGH-PERFORMANCE HYDRAULIC ROCK DRILLS

The DF530L provides extra torque with two rotation motors and male shank adapters. DF530L is a high-performance rock drill offering high rotation speed capacity for general excavations, mining, and quarrying projects.

The Doofor DF530L can be used with a Doofor original drill feed system component kit.

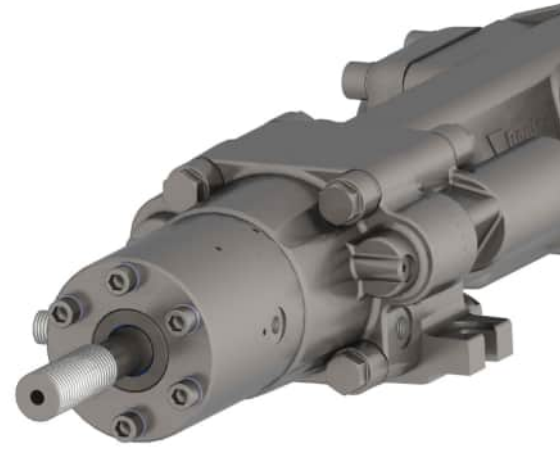

**CIVIL ENGINEERING,
SURFACE AND UNDERGROUND**

TECHNICAL SPECIFICATIONS

DOOFOR DF530L DRIFTERS

NOMINAL POWER CLASS		10 kW	13.4 hp
DRILL HOLE SIZE ⁴⁾		45 mm	1 3/4"
PERCUSSION FLOW		45–55 l/min	11.9–14.5 gpm
PERCUSSION PRESSURE		100–130 bar	1450–1885 psi
LUBRICATION	Air-oil mist	125–200 g/h	4.9–7.8 fl oz/h (1.4–2.3 dl/h)
LUBRICATION PRESSURE		4–7 bar	58–101 psi
LUBRICATION AIR FLOW		200–300 l/min	53–79 gpm
FLUSHING AIR PRESSURE ³⁾		5–12 bar	73–174 psi
FLUSHING AIR FLOW ³⁾		700–1200 l/min	185–317 gpm
FLUSHING WATER PRESSURE ³⁾		5–12 bar	73–174 psi
FLUSHING WATER FLOW ³⁾		25–40 l/min	6.6–10.6 gpm
RECOMMENDED MAXIMUM FEED FORCE		12.5 kN	2810 lbf
SHANK SIZE		Male R28, R32 (R38, T38 in HD model)	
WEIGHT		83 kg	[183 lb]
ROTATION MOTOR MAXIMUM FLOW ¹⁾	2x 20cc	50 l/min	[13.2 gpm]
	2x 32cc	50 l/min	[13.2 gpm]
	2x 40cc	50 l/min	[13.2 gpm]
	2x 50cc	50 l/min	[13.2 gpm]
ROTATION TORQUE ¹⁾	2x 20cc	181 Nm	[131 lb-ft]
	2x 32cc	295 Nm	[218 lb-ft]
	2x 40cc	363 Nm	[268 lb-ft]
	2x 50cc	456 Nm	[336 lb-ft]
ROTATION SPEED MAXIMUM ²⁾	2x 20cc	385 rpm	
	2x 32cc	243 rpm	
	2x 40cc	192 rpm	
	2x 50cc	154 rpm	
ROTATION PRESSURE MAXIMUM ⁵⁾		140 bar	2031 psi

1) Intermittent value.

2) Continuous value. Maximum recommended speed 300 rpm.

3) Actual values vary according to drilling conditions and equipment.

4) Maximum drill hole size in normal drilling applications.

5) Confirm the maximum pressure drop from the manual or the motor specifications.

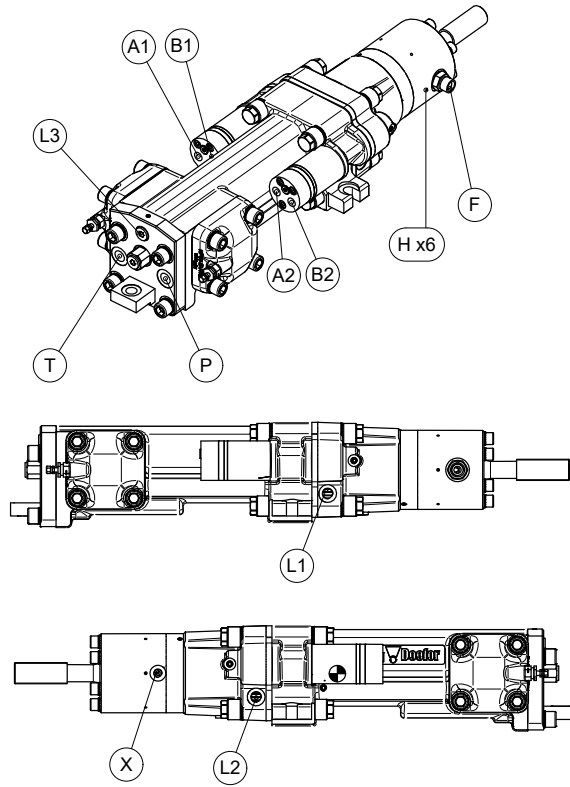

- A1 & A2) G3/8 Rotation A - connected together with a T-adaptor.
- B1 & B2) G3/8 Rotation B - connected together with a T-adaptor.
- F) G1/2 Flushing.
- H) Flushing seal leak indicator hole.
- L1) G3/8 Pressurised air-oil mist lubrication.
- L2) G3/8 Plug, alternative to L1
- L3) Plug.
- P) G1/2 Percussion pressure.
- T) G1/2 Percussion return to tank.
- X) G1/4 Lubrication exit.

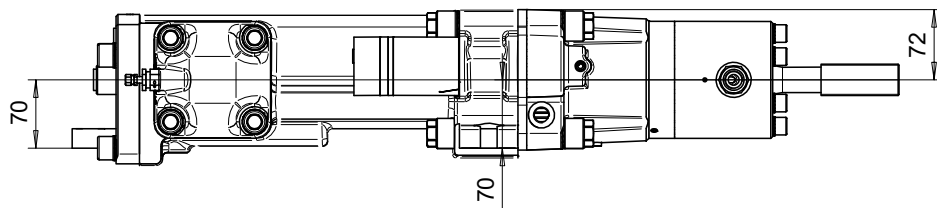
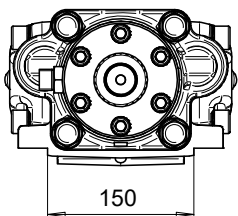
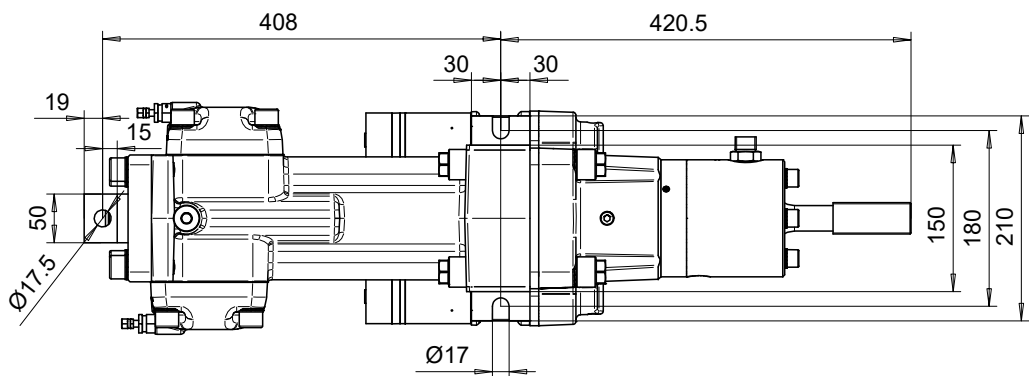

DF530XS HIGH-PERFORMANCE HYDRAULIC ROCK DRILL

Doofor DF530XS is a new generation high-power, high-frequency rock drill used for bolting, general excavations and quarrying. This rock drill combines female or male shank adapters with extra short desing. Flushing media can be air or water. The rock drill is exceptionally compact, allowing operation in confined spaces.

DF530XS uses a high-energy piston shape for high-penetration speed in hard rock drilling operations and is efficient in preserving good drill tool life.

This model can be used with a Doofor original drill feed system component kit.



CIVIL ENGINEERING AND UNDERGROUND

TECHNICAL SPECIFICATIONS

DOOFOR DF530XS DRIFTER

NOMINAL POWER CLASS		10 kW	13.4 hp
DRILL HOLE SIZE ⁴⁾		45 mm	1 3/4"
PERCUSSION FLOW		45–55 l/min	11.9–14.5 gpm
PERCUSSION PRESSURE		100–130 bar	1450–1885 psi
ROTATION MOTOR MAXIMUM FLOW ¹⁾	12.5cc	25 l/min	6.6 gpm
	20cc	25 l/min	6.6 gpm
	32cc	25 l/min	6.6 gpm
	40cc	25 l/min	6.6 gpm
	50cc	25 l/min	6.6 gpm
ROTATION TORQUE ¹⁾	12.5cc	70 Nm	52 lb-ft
	20cc	107 Nm	79 lb-ft
	32cc	177 Nm	131 lb-ft
	40cc	214 Nm	158 lb-ft
	50cc	269 Nm	198 lb-ft
ROTATION PRESSURE MAXIMUM ⁵⁾		140 bar	2031 psi
ROTATION SPEED MAXIMUM ²⁾	12.5cc	506 rpm	
	20cc	326 rpm	
	32cc	205 rpm	
	40cc	163 rpm	
	50cc	130 rpm	
LUBRICATION	Air-oil mist	125–200 g/h	4.9–7.8 fl oz/h (1.4–2.3 dl/h)
LUBRICATION PRESSURE		4–7 bar	58–101 psi
LUBRICATION AIR FLOW		200–300 l/min	53–79 gpm
FLUSHING AIR PRESSURE ³⁾		5–12 bar	73–174 psi
FLUSHING AIR FLOW ³⁾		700–1200 l/min	185–317 gpm
FLUSHING WATER PRESSURE ³⁾		5–12 bar	73–174 psi
FLUSHING WATER FLOW ³⁾		25–40 l/min	6.6–10.6 gpm
RECOMMENDED MAXIMUM FEED FORCE		10 kN	2248 lbf
WEIGHT		70 kg	154 lb
SHANK SIZE		Female or male R25, R28 or R32.	

¹⁾ Intermittent value.

²⁾ Continuous value. Maximum recommended speed 300 rpm.

³⁾ Actual values vary according to drilling conditions and equipment.

⁴⁾ Maximum drill hole size in normal drilling applications.

⁵⁾ Confirm the maximum pressure drop from the manual or the motor specifications.

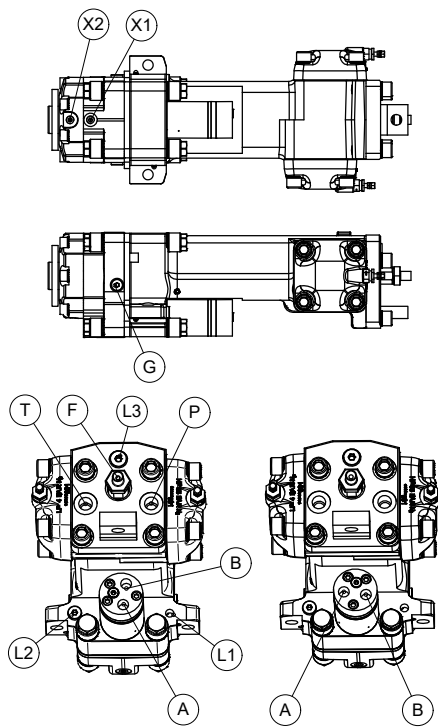

- A) G3/8 Rotation A
- B) G3/8 Rotation B
- F) G3/8 Flushing
- L1) G1/4 Pressurised air-oil mist lubrication.
- L2) G1/4 Plug,
- L3) Plug.
- P1) G1/2 Percussion pressure.
- T) G1/2 percussion return to tank.
- X1 and X2) Lubrication exit.

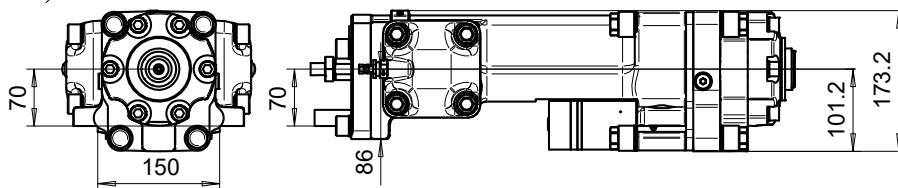
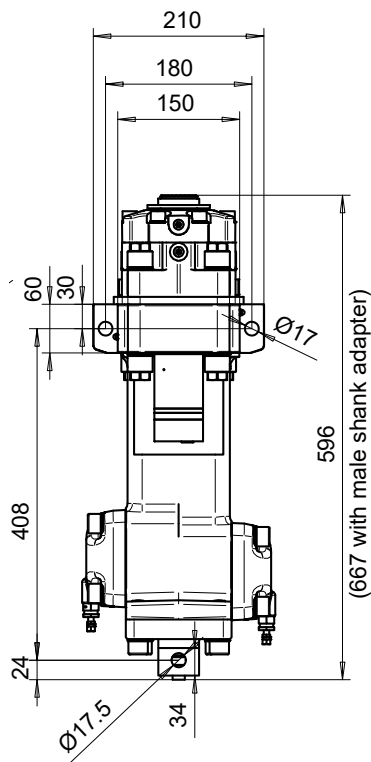

Alternative models for Doofor DF530XS include Doofor DF530X with female hexagonal chuck, DF530S with male shank adapter and Doofor DF530L with two side rotation motors for extra torque.

DF538L HIGH-PERFORMANCE HYDRAULIC ROCK DRILL

Doofor DF538L is a highly efficient hydraulic rock drill equipped with two rotation motors capable of generating high levels of torque. This rock drill features a robust gearbox which maximizes durability for surface and underground use. DF538L application varies from general excavations, tunneling or mining. This model can be used with a Doofor original drill feed system component kit.

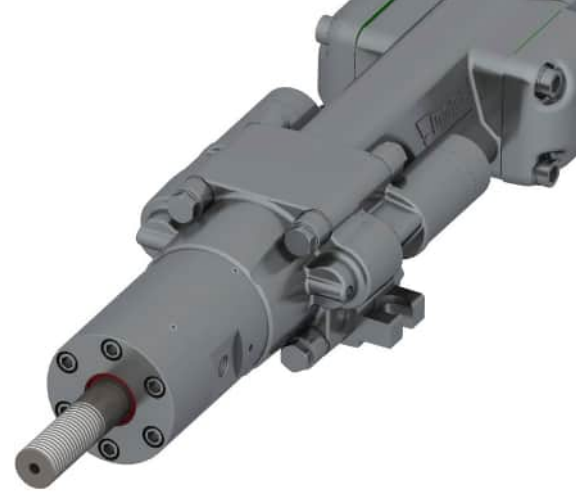

**CIVIL ENGINEERING,
SURFACE AND UNDERGROUND**

TECHNICAL SPECIFICATIONS

DOOFOR DF538L DRIFTER

NOMINAL POWER CLASS		13 kW	17.4 hp
DRILL HOLE SIZE ⁴⁾		57 mm	2 1/4"
PERCUSSION FLOW		65–85 l/min	17–23 gpm
PERCUSSION PRESSURE		110–140 bar	1600–2050 psi
ROTATION MOTOR MAXIMUM FLOW ¹⁾	2x 20cc	50 l/min	13.2 gpm
	2x 32cc	50 l/min	13.2 gpm
	2x 40cc	50 l/min	13.2 gpm
	2x 50cc	50 l/min	13.2 gpm
ROTATION TORQUE ¹⁾	2x 20cc	181 Nm	131 lb-ft
	2x 30cc	295 Nm	218 lb-ft
	2x 40cc	363 Nm	268 lb-ft
	2x 50cc	456 Nm	336 lb-ft
ROTATION PRESSURE MAXIMUM ⁵⁾		140 bar	2031 psi
ROTATION SPEED MAXIMUM ²⁾	2x 20cc	385 rpm	
	2x 32cc	243 rpm	
	2x 40cc	192 rpm	
	2x 50cc	154 rpm	
LUBRICATION	Air-oil mist	150–250 g/h	5.9–9.8 fl oz/h (1.7–2.9 dl/h)
LUBRICATION PRESSURE		4–7 bar	58–101 psi
LUBRICATION AIR FLOW		200–300 l/min	53–79 gpm
FLUSHING AIR PRESSURE ³⁾		5–10 bar	73–145 psi
FLUSHING AIR FLOW ³⁾		1500–2500 l/min	396–660 gpm
FLUSHING WATER PRESSURE ³⁾		4–12 bar	58–174 psi
FLUSHING WATER FLOW ³⁾		30–40 l/min	8–11 gpm
RECOMMENDED MAXIMUM FEED FORCE		12.5 kN	2810 lbf
WEIGHT		83 kg	183 lb
SHANK SIZE		R32, R38, T38	

¹⁾ Intermittent value.

²⁾ Continuous value. Maximum recommended speed 300 rpm.

³⁾ Actual values vary according to drilling conditions and equipment.

⁴⁾ Maximum drill hole size in normal drilling applications.

⁵⁾ Confirm the maximum pressure drop from the manual or the motor specifications.

DIMENSIONS

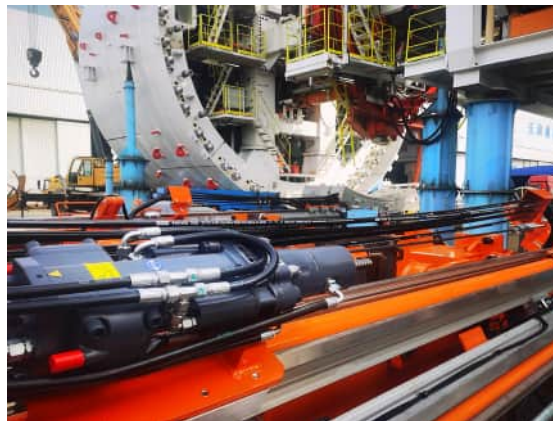
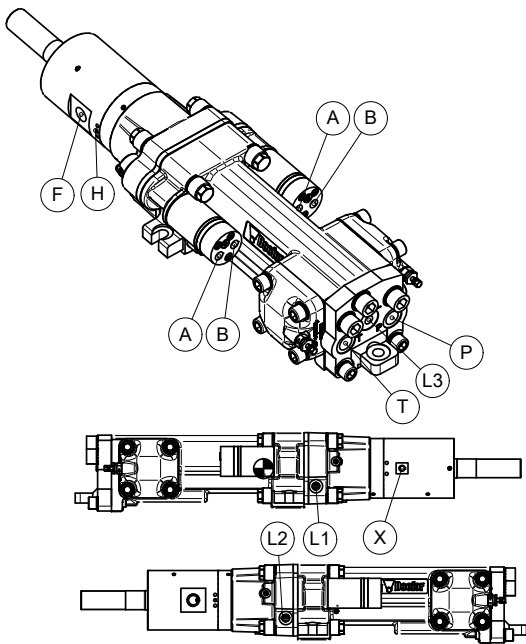
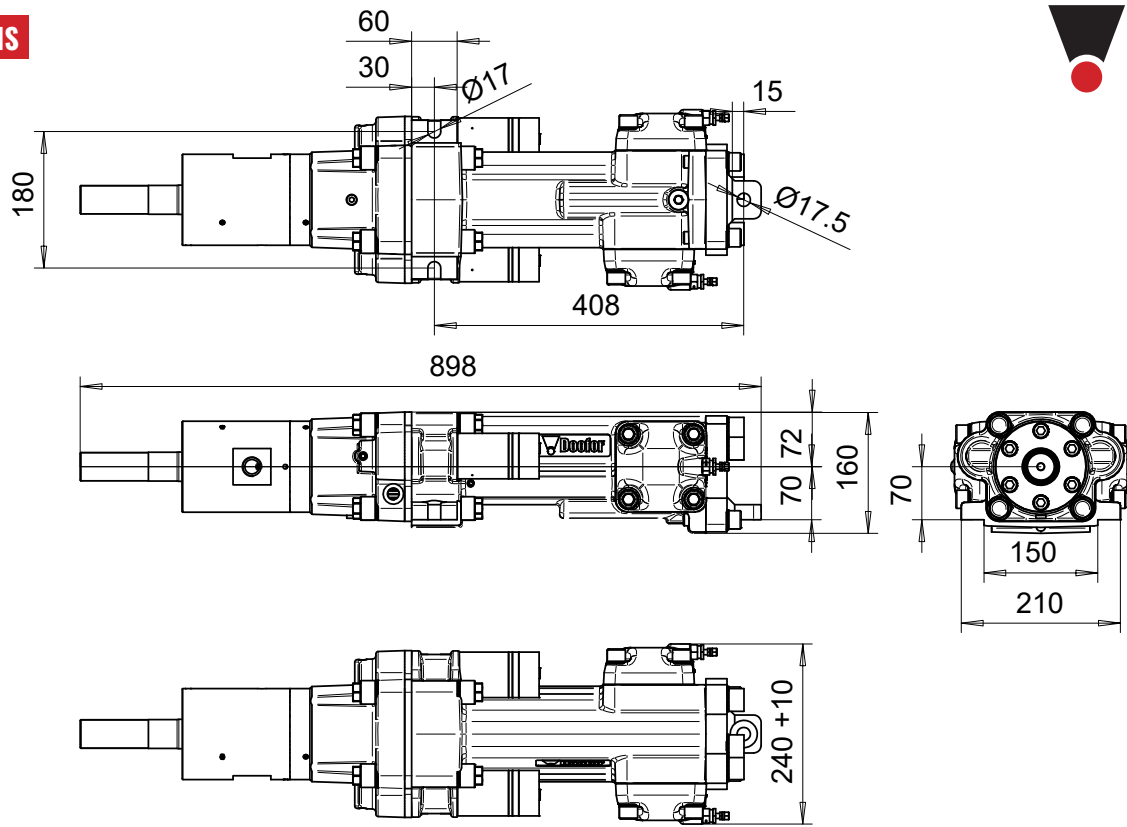

- A1 & A2) G3/8 Rotation A - connected together with a T-adapter.
- B1 & B2) G3/8 Rotation B - connected together with a T-adapter.
- F) G3/4 Flushing.
- H) Flushing seal leak indicator hole.
- L1) G3/8 Pressurised air-oil mist lubrication.
- L2) G3/8 Plug, alternative to L1
- L3) G3/8 Breathing. Connect to L1 or L2.
- P) G3/4 Percussion pressure.
- T) G3/4 Percussion return to tank.
- X) G1/4 Lubrication exit.

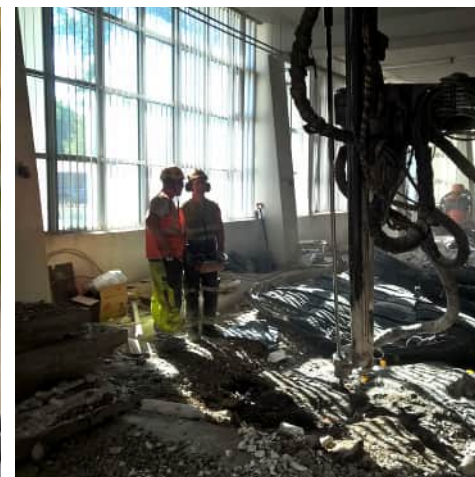

DF540L-BLT HIGH-PERFORMANCE HYDRAULIC ROCK DRILL

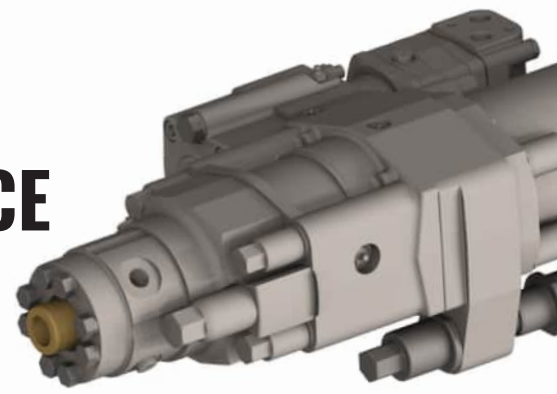

UNDERGROUND

Doofor DF540L-BLT is a hydraulic rock drill designed for bolting, general excavations, and underground production drilling. It has a very low overhead, only 82.5mm from the center line. The rotation motor of the Doofor DF540L-BLT can be installed on the right-hand or the left-hand side. Flushing media can be water or air. Optimized internal oil flow construction effectively preserves hydraulic power.

TECHNICAL SPECIFICATIONS

DOOFOR DF540L-BLT DRIFTER

NOMINAL POWER CLASS		14 kW	18.8 hp
DRILL HOLE SIZE ⁵⁾		64 mm	2 1/2"
PERCUSSION FLOW		90 l/min	23.8 gpm
PERCUSSION PRESSURE		140 bar	2030 psi
ROTATION MOTOR MAXIMUM FLOW ¹⁾⁴⁾	80cc	80 l/min	21.1 gpm
	125cc	90 l/min	23.8 gpm
	160cc	90 l/min	23.8 gpm
ROTATION TORQUE ¹⁾	80cc	504 Nm	372 lb-ft
	125cc	796 Nm	587 lb-ft
	160cc	975 Nm	719 lb-ft
ROTATION PRESSURE MAXIMUM ⁶⁾		175 bar	2540 psi
ROTATION SPEED MAXIMUM ²⁾	80cc	498 rpm	
	125cc	369 rpm	
	160cc	289 rpm	
LUBRICATION	Air-oil mist	200-300 g/h	7.8-11.7 fl oz/h (2.3-3.5 dl/h)
LUBRICATION PRESSURE		4-7 bar	58-101 psi
LUBRICATION AIR FLOW		200-300 l/min	53-79 gpm
FLUSHING AIR PRESSURE ³⁾		5-7 bar	73-101 psi
FLUSHING AIR FLOW ³⁾		4000 l/min	1057 gpm
FLUSHING WATER FLOW ³⁾		150 l/min	39.6 gpm
RECOMMENDED MAXIMUM FEED FORCE		20 kN	4497 lbf
WEIGHT		144 kg	317 lb
SHANK SIZE		Male R32, R38, T38 and female R32.	

1) Intermittent value.

2) Continuous value. Maximum recommended speed 250 rpm.

3) Actual values vary according to drilling conditions and equipment.

4) Value for default OMS motors only.

5) Maximum drill hole size in normal drilling applications.

6) Confirm the maximum pressure drop from the manual or the motor specifications.



- A) G1/2 Rotation A
- B) G1/2 Rotation B
- X) G1/4 Lubrication exit
- F) G1/2 Flushing
- H) Flushing seal leak indicator hole, 4 pcs
- L) G1/4 Pressurised air-oil mist lubrication
- P1) G3/4 Percussion pressure
- P2) G3/4 Plug, alternative to P1, 2 pcs
- T1) G1/4 Percussion return to tank
- T2) G3/4 Plug, alternative to T1, 2 pcs

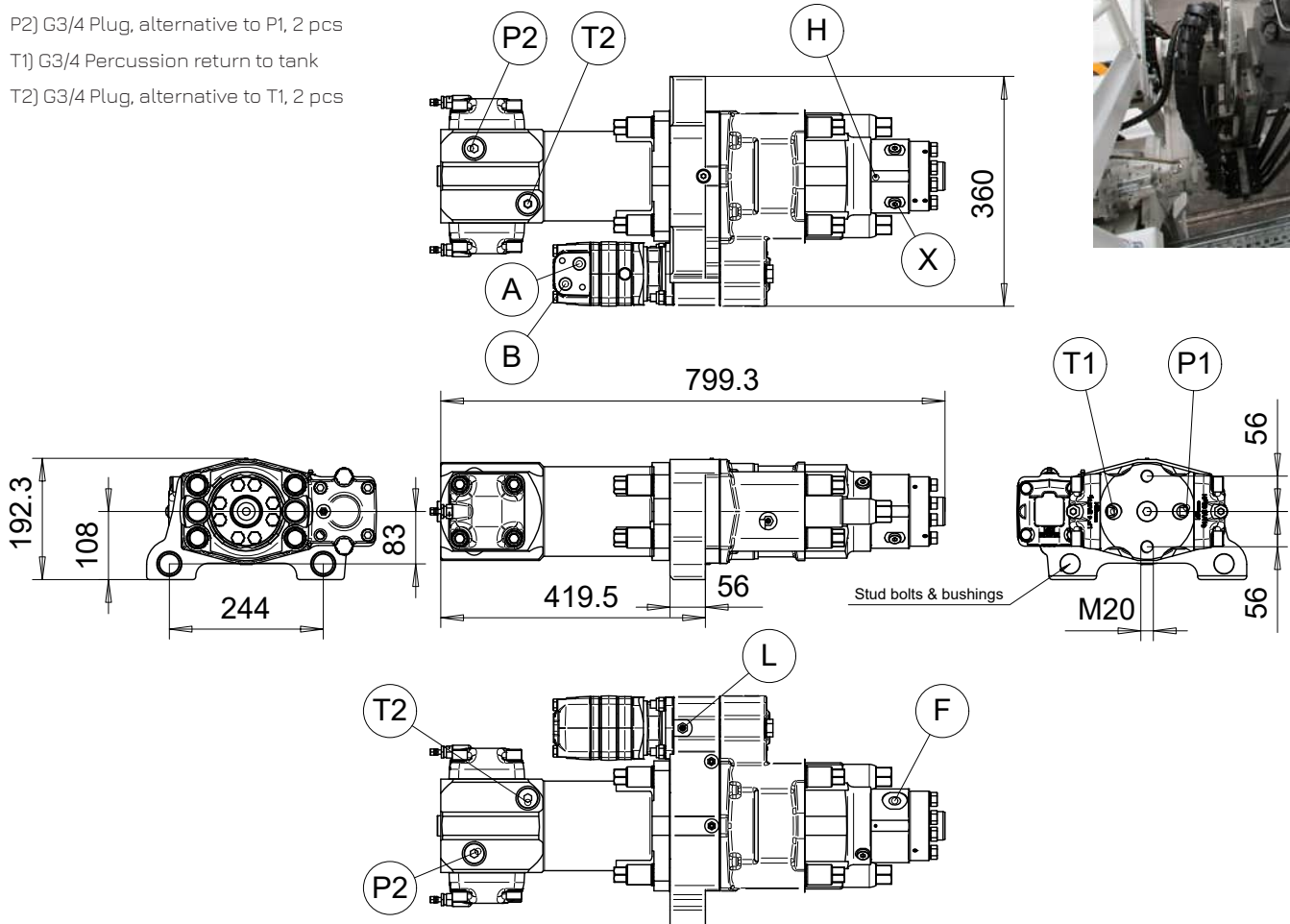

Motor can be on the left or on the right side. Motor ports can be turned. Back port versions of motor are available.

Flushing head can be turned 180 degrees. Accumulators can be turned to any of the four positions (depending on motor).

Doofor DF540L-BLT can be equipped with BLTG-, BLTF- and 2M options and a standard Doofor flushing system, similar to DF550L or DF560L.

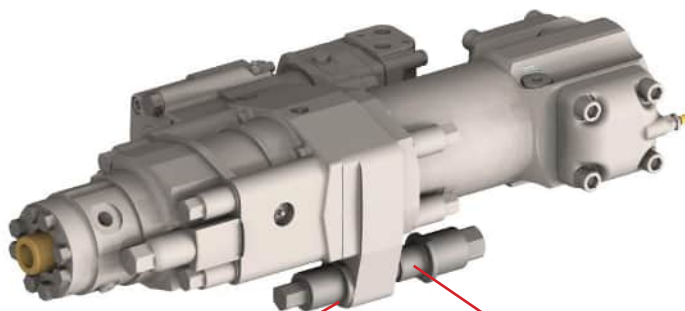

EMBEDDED BUSHINGS

STUD BOLT AND HAT NUT

DF550L HIGH-PERFORMANCE HYDRAULIC ROCK DRILL



Doofor DF550L maintains its durable, universal structure similar to its predecessors. This rock drill was designed with power and multipurpose in mind. The rotation motor can be installed on the right or left-hand side and further customization is possible with BLT attachment option for bolting application.

The DF550L has a separated flushing box and flushing media can be water or air. The standard DF550L model can be used to enhance your drilling operations in projects including underground production drilling, tunnelling, and bolting. This rock drill has a very low profile, only 84mm from the drill center line.

SURFACE AND UNDERGROUND

TECHNICAL SPECIFICATIONS

DOOFOR DF550L DRIFTER

NOMINAL PERCUSSION POWER		17 kW	22.8 hp
DRILL HOLE SIZE ⁵⁾		76 mm	3"
PERCUSSION FLOW		90–120 l/min	23.8–31.7 gpm
PERCUSSION PRESSURE		80–160 bar	1160–2321 psi
ROTATION MOTOR MAXIMUM FLOW ^{1) 4)}	80cc	80 l/min	21.1 gpm
	100cc	90 l/min	23.8 gpm
	125cc	90 l/min	23.8 gpm
	160cc	90 l/min	23.8 gpm
	200cc	90 l/min	23.8 gpm
ROTATION TORQUE ¹⁾	80cc	504 Nm	372 lb-ft
	100cc	634 Nm	468 lb-ft
	125cc	796 Nm	587 lb-ft
	160cc	975 Nm	719 lb-ft
	200cc	1170 Nm	863 lb-ft
ROTATION PRESSURE ^{4) 6)} (MAXIMUM)		175 bar (275 bar)	2540 psi (3989 psi)
ROTATION SPEED MAXIMUM ²⁾	80cc	498 rpm	
	100cc	461 rpm	
	125cc	369 rpm	
	160cc	289 rpm	
	200cc	230 rpm	
LUBRICATION	Air-oil mist	200–300 g/h	7.8–11.7 fl oz/h (2.3–3.5 dl/h)
LUBRICATION PRESSURE		6–7 bar	87–101 psi
LUBRICATION AIR FLOW		200–300 l/min	53–79 gpm
FLUSHING AIR PRESSURE ³⁾		5–7 bar	73–101 psi
FLUSHING AIR FLOW ³⁾		4000 l/min	1057 gpm
FLUSHING WATER FLOW ³⁾		50–150 l/min	13–40 gpm
RECOMMENDED MAXIMUM FEED FORCE		20 kN	4497 lbf
WEIGHT		151 kg	333 lb
SHANK SIZE		R32, R38, T38 (T45 with special options)	

¹⁾ Intermittent value.

²⁾ Continuous value. Maximum recommended speed 250 rpm.

³⁾ Actual values vary according to drilling conditions and equipment.

⁴⁾ Value for default OMS motors only.

⁵⁾ Maximum drill hole size in normal drilling applications.

⁶⁾ Confirm the maximum pressure drop from the manual or the motor specifications.

DIMENSIONS

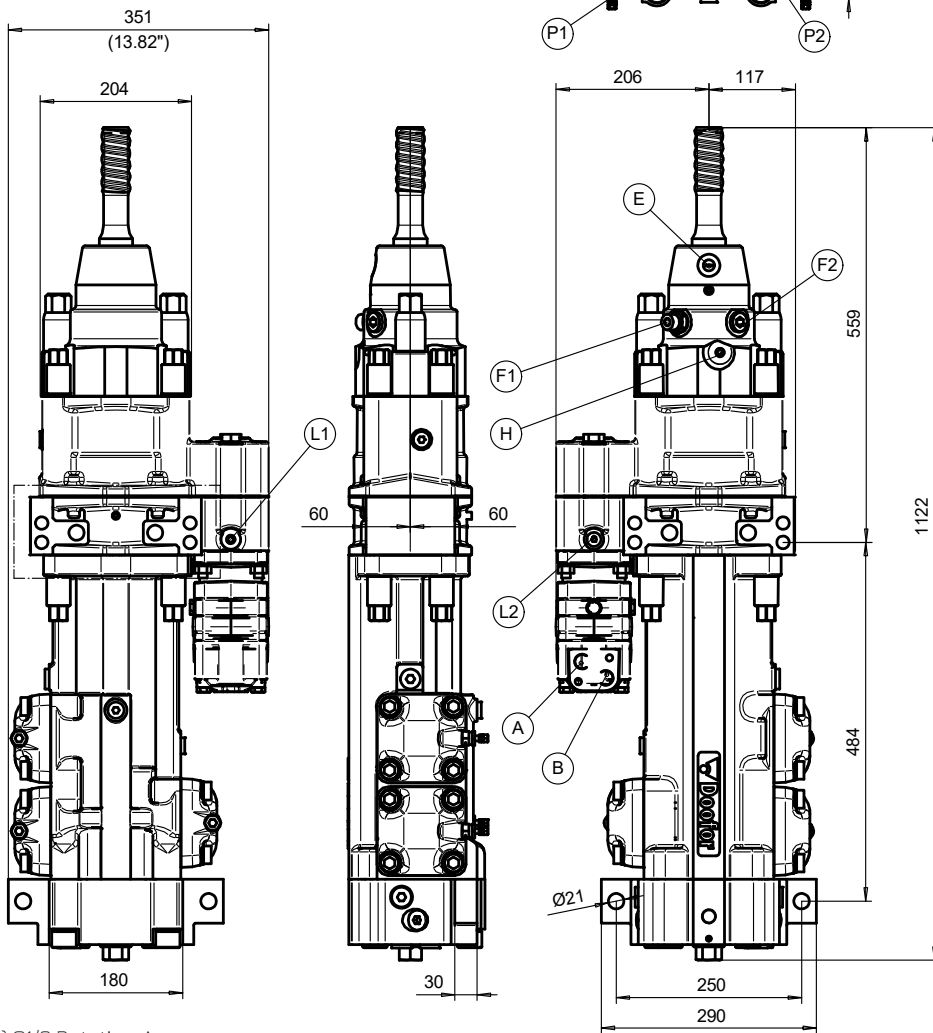

- A) G1/2 Rotation A
- B) G1/2 Rotation B
- E) G3/8 Lubrication exit
- F1) G1/2 Flushing (Optional: G3/4, JIC7/8, JIC 1 1/16)
- F2) G1/2 Alternative to F1 (same options)
- H) Flushing seal leak indicator hole
- L1) G1/4 Pressurised air-oil mist lubrication
- L2) G1/4 Plug, alternative to L1
- P1) G3/4 Percussion pressure
- P2) G3/4 Plug, alternative to P1
- T1) G3/4 percussion return to tank
- T2) G3/4 Plug, alternative to L1

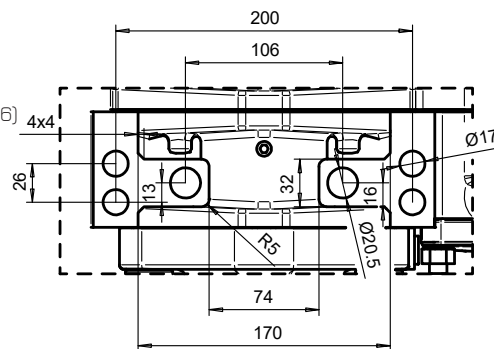

DOOFOR DF550S

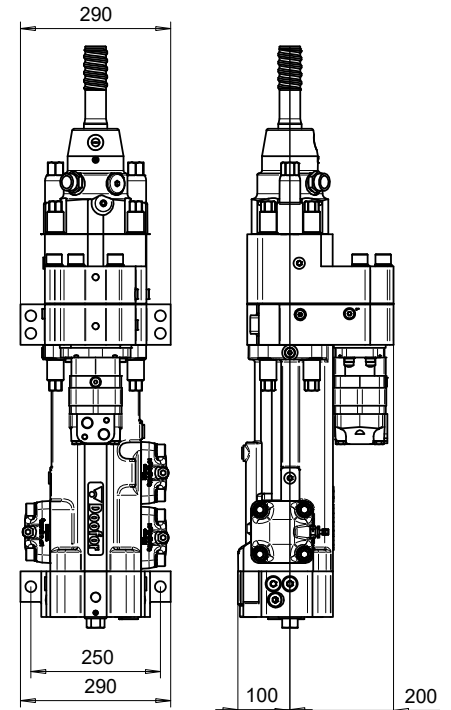

An alternative variant, Doofor DF550S has the rotation motor situated on top of the rock drill. While the dimensioning and mounting system changes, the performance characteristics are the same as Doofor DF550L. The DF550S rock drill uses the same shank adapters as DF560L and DF560S.

Motor can be on the left or on the right side. Motor ports can be turned. Back port versions of motor are available. Flushing head can be turned 180 degrees.

Accumulators can be turned to any of the four positions (depending on motor.)

Doofor DF550L can be equipped with BLT-, BLTG-, BLTF- and 2M options. Special heatproof version for blast furnace tap hole drilling available.



DF560L HIGH-PERFORMANCE HYDRAULIC ROCK DRILL



SURFACE AND UNDERGROUND

Doofor DF560L is a next generation hydraulic rock drill designed to ensure high-drilling capacity and optimal drill steel lifetime. Patented percussion channeling minimizes the number of parts requiring maintenance, making this rock drill one of the best on the market in terms of power to weight ratio. Original modular design makes this rock drill also one of the easiest to service. The rotation motor can be installed on the right or left-hand side. Flushing media can be air or water. Customization options include BLT and BLTF variants for bolting and grouting.

DF560L can be used in underground production drilling and tunnelling applications. This rock drill has a very low profile, only 84mm from the drill center line.

TECHNICAL SPECIFICATIONS

DOOFOR DF560L DRIFTER

NOMINAL PERCUSSION POWER		20 kW	26.8 hp
DRILL HOLE SIZE ⁵⁾		89 mm	3 1/2"
PERCUSSION FLOW		110–130 l/min	29.1–34.3 gpm
PERCUSSION PRESSURE		80–150 bar	1160–2176 psi
ROTATION MOTOR MAXIMUM FLOW ^{1) 4)}	80cc	80 l/min	21.1 gpm
	100cc	90 l/min	23.8 gpm
	125cc	90 l/min	23.8 gpm
	160cc	90 l/min	23.8 gpm
	200cc	90 l/min	23.8 gpm
ROTATION TORQUE ¹⁾	80cc	504 Nm	372 lb-ft
	100cc	634 Nm	468 lb-ft
	125cc	796 Nm	587 lb-ft
	160cc	975 Nm	719 lb-ft
	200cc	1170 Nm	863 lb-ft
ROTATION PRESSURE ^{4) 6)} (MAXIMUM)		175 bar (275 bar)	2540 psi (3989 psi)
ROTATION SPEED MAXIMUM ²⁾	80cc	498 rpm	
	100cc	461 rpm	
	125cc	369 rpm	
	160cc	289 rpm	
	200cc	230 rpm	
LUBRICATION	Air-oil mist	200–300 g/h	7.8–11.7 fl. oz/h (2.3–3.5 dl/h)
LUBRICATION PRESSURE		6–7 bar	87–101 psi
LUBRICATION AIR FLOW		200–300 l/min	53–79 gpm
FLUSHING AIR PRESSURE ³⁾		5–7 bar	73–101 psi
FLUSHING AIR FLOW ³⁾		4000 l/min	1057 gpm
FLUSHING WATER FLOW ³⁾		50–150 l/min	13–40 gpm
RECOMMENDED MAXIMUM FEED FORCE		20 kN	4497 lbf
WEIGHT		151 kg	333 lb
SHANK SIZE		R32, R38, T38, T45	

¹⁾ Intermittent value.

²⁾ Continuous value. Maximum recommended speed 250 rpm.

³⁾ Actual values vary according to drilling conditions and equipment.

⁵⁾ Maximum drill hole size in normal drilling applications.

⁴⁾ Value for default DMS motors only.

⁶⁾ Confirm the maximum pressure drop from the manual or the motor specifications.

DIMENSIONS

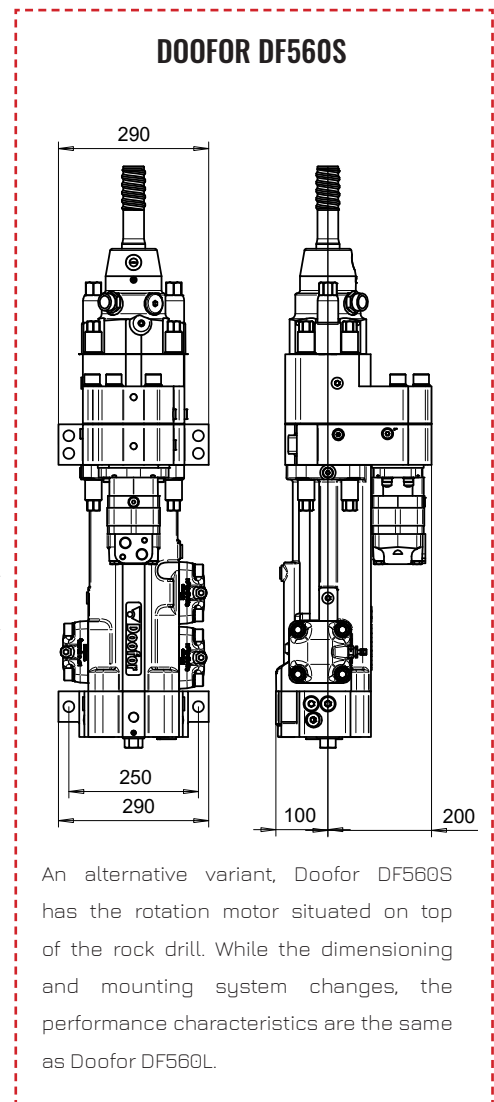
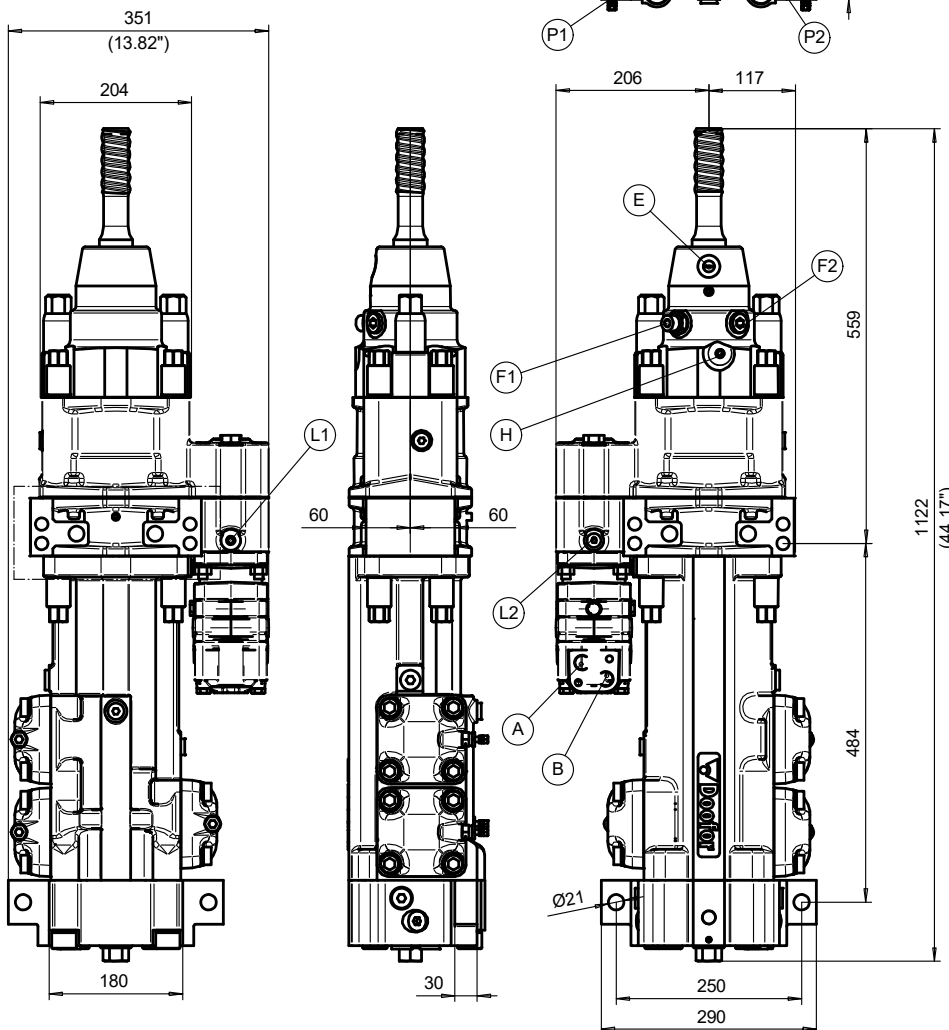

An alternative variant, Doofor DF560S has the rotation motor situated on top of the rock drill. While the dimensioning and mounting system changes, the performance characteristics are the same as Doofor DF560L.

- A) G1/2 Rotation A
- B) G1/2 Rotation B
- E) G3/8 Lubrication exit
- F1) G1/2 Flushing (Optional: G3/4, JIC7/8, JIC 1 1/2)
- F2) G1/2 Alternative to F1 (same options)
- H) Flushing seal leak indicator hole
- L1) G1/4 Pressurised air-oil mist lubrication
- L2) G1/4 Plug, alternative to L1
- P1) G3/4 Percussion pressure
- P2) G3/4 Plug, alternative to P1
- T1) G3/4 percussion return to tank
- T2) G3/4 Plug, alternative to L1

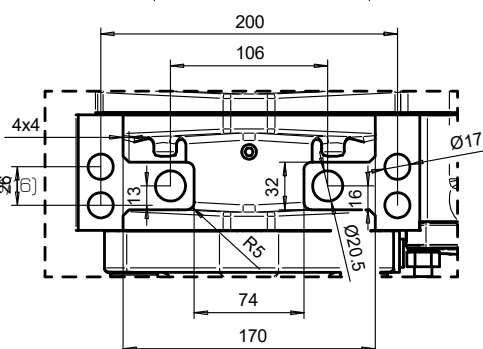

Motor can be on the left or on the right side. Motor ports can be turned. Back port versions of motor are available. Flushing head can be turned 180 degrees. Accumulators can be turned to any of the four positions (depending on motor) Doofor DF560L can be equipped with BLT-, BLTG-, BLTF- and 2M options.



DFR5 HIGH-PERFORMANCE HYDRAULIC ROCK DRILL

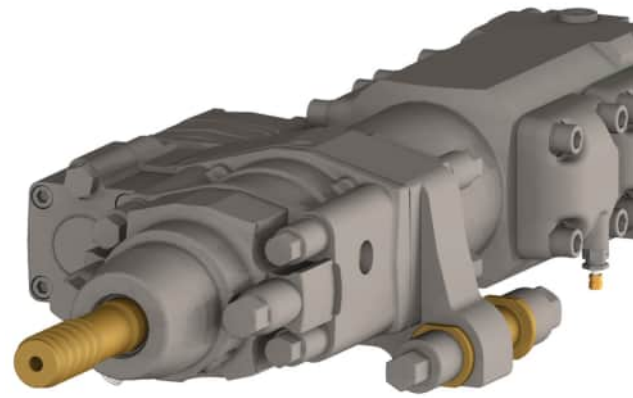

Doofor DFR5 is a high-frequency hydraulic rock drill specially designed for underground production drilling and tunneling. The rock drill utilizes high percussion pressure to gain effective results. The Doofor DFR5 has a very low overhead, only 84mm from the drill center line. The rotation motor of the Doofor DFR5 can be installed on the right hand or the left hand side. The rock drill uses air or water flushing. Available in 19 kW and 21 kW versions.

UNDERGROUND

TECHNICAL SPECIFICATIONS

DOOFOR DFR5 DRIFTER

NOMINAL PERCUSSION POWER		19-21 kW	25.5-28.2 hp
OPTIMAL MAXIMUM HOLE SIZE		89-102 mm	3 1/2"-4"
PERCUSSION FLOW AT 200 BAR		125 l/min	33.0 gpm
PERCUSSION PRESSURE MAX		200 bar	2900 psi
ROTATION MOTOR MAXIMUM FLOW ¹⁾	80cc	80 l/min	21.1 gpm
	125cc	90 l/min	23.8 gpm
	160cc	90 l/min	23.8 gpm
ROTATION TORQUE ¹⁾	80cc	504 Nm	372 lb-ft
	125cc	796 Nm	587 lb-ft
	160cc	975 Nm	719 lb-ft
ROTATION PRESSURE MAXIMUM ⁵⁾		175 bar	2540 psi
ROTATION SPEED MAXIMUM ³⁾	80cc	498 rpm	
	125cc	369 rpm	
	160cc	289 rpm	
LUBRICATION	Air-oil mist	200-300 g/h	7.8-11.7 fl oz/h (2.3-3.5 dl/h)
LUBRICATION PRESSURE		6-7 bar	87-101 psi
LUBRICATION AIR FLOW		200-300 l/min	53-79 gpm
FLUSHING AIR PRESSURE ¹⁾		5-7 bar	73-101 psi
FLUSHING AIR FLOW ¹⁾		4000 l/min	1057 gpm
FLUSHING WATER FLOW ¹⁾		50-150 l/min	13-40 gpm
RECOMMENDED MAXIMUM FEED FORCE		20 kN	4497 lbf
MAXIMUM OPERATING OIL TEMPERATURE		70 °C	158 °F
WEIGHT		206 kg	454 lbs
SHANK SIZE		R32, R38, T38, T45	

¹⁾ Intermittent value.

²⁾ Actual values vary according to drilling conditions and equipment.

³⁾ Continuous value. Maximum recommended speed 250 rpm.

⁵⁾ Confirm the maximum pressure drop from the manual or the motor specifications.

DIMENSIONS

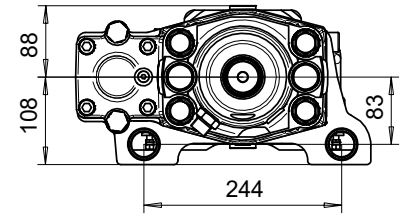
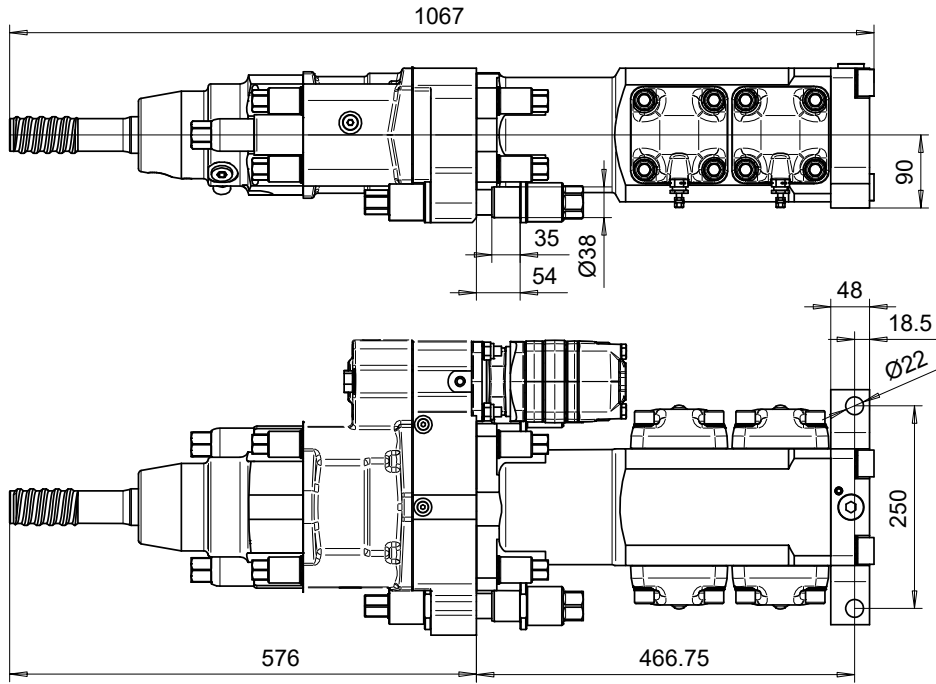

DOOFOR DFR5S

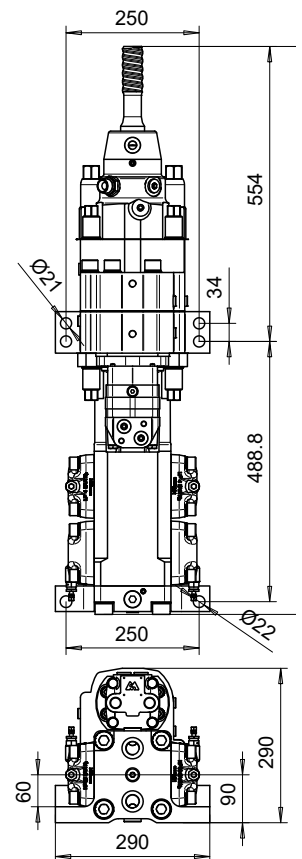

An alternative variant, Doofor DFR5S has the rotation motor situated on top of the rock drill. While the dimensioning and mounting system changes, the performance characteristics are the same as Doofor DFR5S. Available in 19 kW and 21 kW versions.

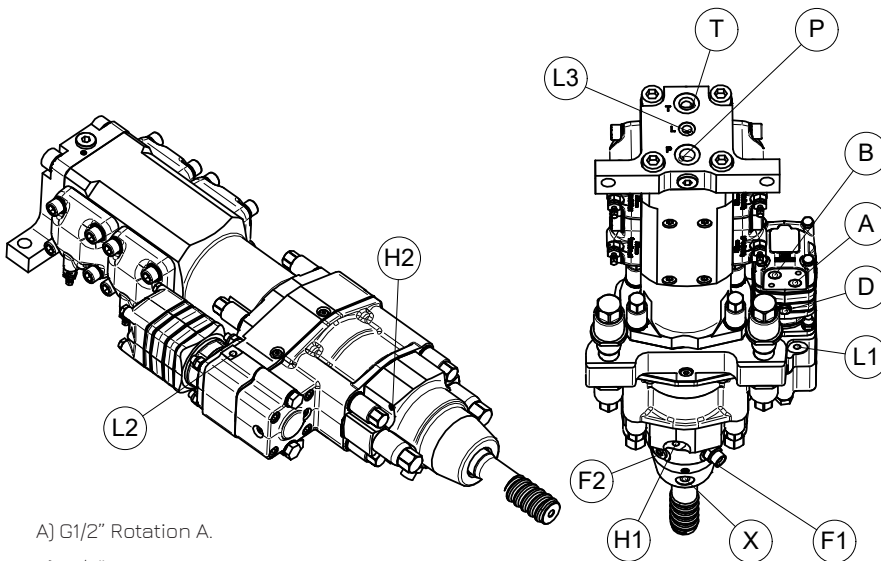

- A) G1/2" Rotation A.
- B) G1/2" Rotation B.
- D) G1/4" Motor drain. Connection not required.
- F1) G3/4" Flushing. Alternative sizes for special adapters available.
- F2) G1/2" Plug. Alternative port for special flushing adapter.
- H1) G1/4 Flushing leak indicator hole.
- H2) 4x Flushing leak indicator holes.
- L1) G1/4" Pressurised air-oil mist lubrication inlet.
- L2) G1/4" Alternative pressurised air-oil mist inlet port.
- L3) G3/8" Breathing, connected to L1 or L2.
- P) G3/4" Percussion pressure.
- T) G3/4" Percussion return to tank.
- X) G1/4" Lubrication exit. A short hose can be connected here to redirect the flow.



DFR8

HIGH-PERFORMANCE HYDRAULIC ROCK DRILL

The newcomer of the Doofor rock drill family, the Doofor DFR8 is a next-generation high-frequency hydraulic rock drill. The Doofor DFR8 has motor on the top side of the drill. The rock drill has hydraulic cushioning and extractor as standard features. The extractor allows easy detaching of drill rods and the dampening system improves the drilling capability of the rock drill.

Protected by various patents.

Doofor DFR8 is available in 22 kW and 25 kW versions.



SURFACE AND UNDERGROUND

TECHNICAL SPECIFICATIONS

DOOFOR DFR8 DRIFTER

NOMINAL MAXIMUM PERCUSSION POWER		22 kW / 25 kW	29.5 hp / 34 hp
OPTIMAL MAXIMUM HOLE SIZE		102-127 mm	4-5"
PERCUSSION FLOW	22 kW	135 l/min (varies)	35.7 gpm (varies)
	25 kW	148 l/min (range 130-148)	39.1 gpm (range 34.3-39.1)
RECOMMENDED PERCUSSION PRESSURE		130-170 bar	1885-2465 psi
ROTATION MOTOR MAXIMUM FLOW ¹⁾	200cc	90 l/min	23.8 gpm
	250cc ³⁾	90 l/min	23.8 gpm
	315cc	90 l/min	23.8 gpm
	400cc	90 l/min	23.8 gpm
ROTATION TORQUE ¹⁾	200cc	1329 Nm	980 lb-ft
	250cc ³⁾	1606 Nm	1180 lb-ft
	315cc	1846 Nm	1362 lb-ft
	400cc	1827 Nm	1347 lb-ft
ROTATION PRESSURE MAXIMUM ¹⁾⁶⁾		225 bar	3263 psi
ROTATION SPEED MAXIMUM ²⁾	200cc	203 rpm	
	250cc ³⁾	162 rpm	
	315cc	130 rpm	
	400cc	102 rpm	
LUBRICATION	Air-oil mist	300-500 g/h	11.7-17.9 fl oz/h (3.5-5.3 dl/h)
LUBRICATION PRESSURE		5-8 bar	73-1116 psi
LUBRICATION AIR FLOW		400-500 l/min	105-132 gpm
FLUSHING AIR PRESSURE ⁴⁾		7-10 bar	101-145 psi
FLUSHING AIR FLOW ⁴⁾		6000-15000 l/min	1600-4000 gpm
FLUSHING WATER FLOW ⁴⁾		100-300 l/min	26-80 gpm
RECOMMENDED MAXIMUM FEED FORCE		22 kN	4946 lbf
MAXIMUM OPERATING OIL TEMPERATURE ⁵⁾		65 °C	149 °F
WEIGHT		260 kg	573 lb
SHANK SIZE		T38, T45, T51 and GT60 (Other sizes possible)	

¹⁾ Intermittent value.

²⁾ Continuous operation values.

³⁾ 250cc motor recommended.

⁴⁾ Value highly dependent on drilling conditions.

⁵⁾ Oil grade must be suitable for the operating temperatures.

⁶⁾ Confirm the maximum pressure drop from the manual or the motor specifications.

DIMENSIONS

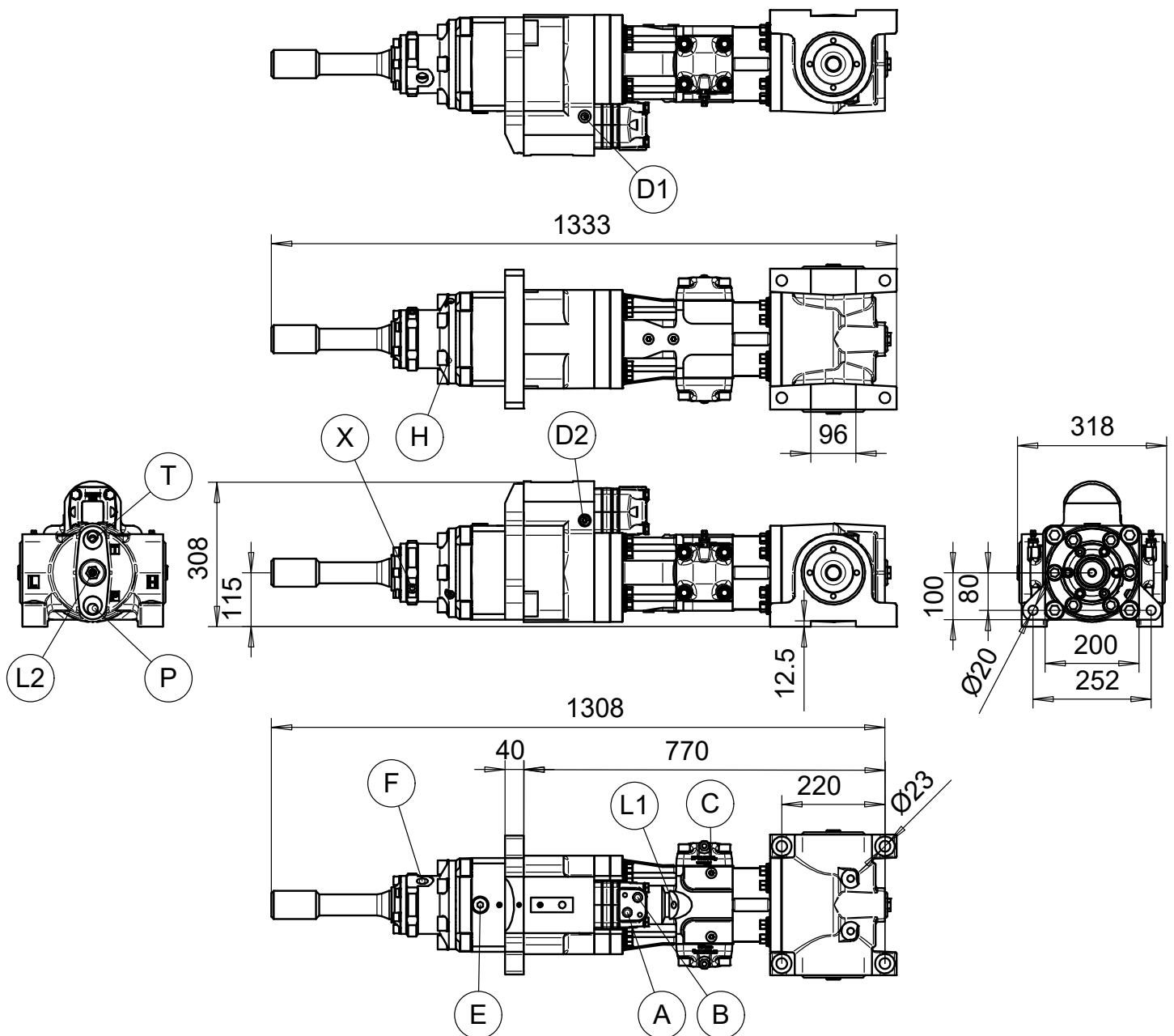

- A) G1/2" Rotation A.
- B) G1/2" Rotation B.
- C) G3/8" Optional auxiliary dampening system control port. Use requires special setup. More information about the requirements in the user's manual.
- D1) G1/4" Motor drain.
- D2) G1/4" Alternative motor drain.
- E) G3/4" Optional auxiliary extractor system control port. Use requires special setup, more information about the requirements in the user's manual.
- F) G3/4" Flushing.
- H) 6x Flushing leak indicator holes. If flushing water leaks from these holes the flushing seals must be immediately replaced.
- L1) G3/8" Pressurised air-oil mist lubrication.
- L2) G3/8" Breathing. Connected with a T-adapter to the lubrication port L1.
- P) G1 1/4" Percussion pressure.
- T) G1 1/4" Percussion return to tank.
- X) G1/4" Lubrication exit. A short hose can be connected here to redirect the flow.



OPTIONS FOR DOOFOR DFR5 DF560L DF550L AND DF540L HYDRAULIC ROCK DRILLS

Besides different shank adapters and rotation motor sizes, variety of options are available for Doofor DF540L, DF550L, DF560L and DFR5 hydraulic rock drills. Options improve the performance and make the product more suitable for your application.

2M option effectively doubles the torque of the rock drill.

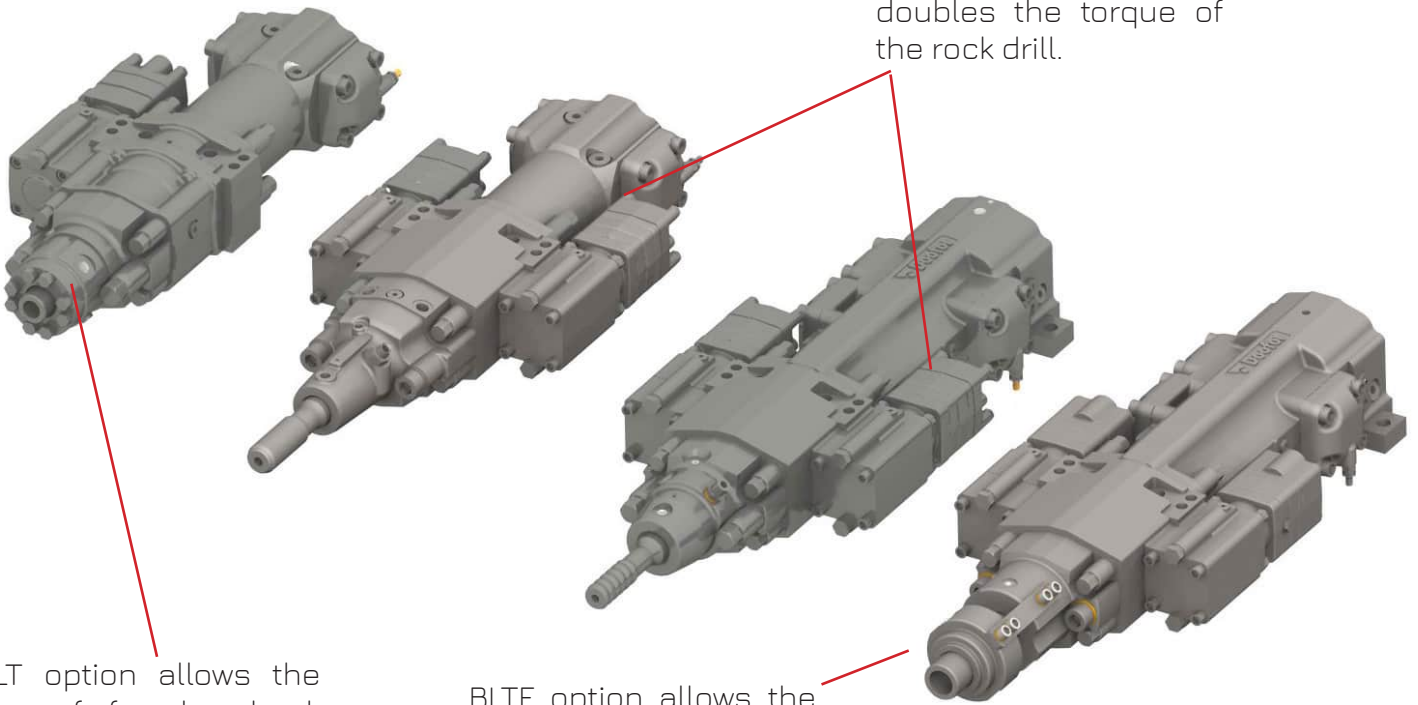

BLT option allows the use of female shank adapters up to R32. Extra seals enhance durability.

BLTG option adds even more seals, improved shank support and uses male shank adapters.

BLTF option allows the use of female shank adapters up to T38/R38 size.

Flushing head is completely separated, making it easy to use grouting fluids.



2M OPTION FOR HIGH TORQUE WITH TWO ROTATION MOTORS



2M option replaces the gear box with two rotation motor version. It can be attached to the Doofor DF540L, DF550L, DF560L, DFR5 and DFR8 rock drills. The option improves the performance of the rock drill by increasing rotation torque. 2M-option can be combined with various different options.

TECHNICAL SPECIFICATIONS

2M OPTION FOR DOOFOR DF540L, DF550L, DF560L AND DFR5

ROTATION MOTOR MAXIMUM FLOW ^{1) 3)}	2x 80cc	160 l/min	42.2 gpm
	2x 125cc	180 l/min	47.6 gpm
	2x 160cc	180 l/min	47.6 gpm
ROTATION TORQUE ¹⁾	2x 80cc	1008 Nm	744 lb-ft
	2x 125cc	1592 Nm	1174 lb-ft
	2x 160cc	1950 Nm	1438 lb-ft
ROTATION PRESSURE MAXIMUM ⁴⁾		175 bar	2540 psi
ROTATION MOTOR MAXIMUM SPEED ²⁾	2x 80cc	498 rpm	
	2x 125cc	369 rpm	
	2x 160cc	289 rpm	

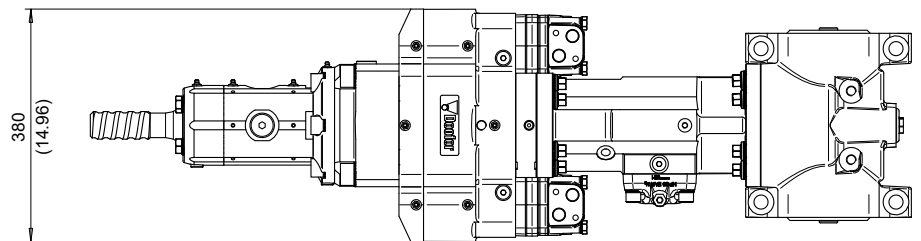
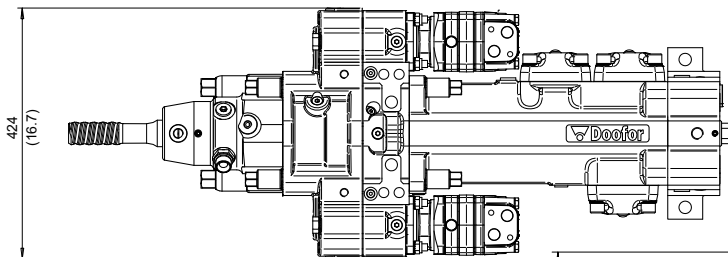

2M OPTION FOR DOOFOR DFR8

ROTATION MOTOR MAXIMUM FLOW ^{1) 3)}	2x 250cc	180 l/min	47.6 gpm
	2x 315cc	180 l/min	47.6 gpm
	2x 400cc	180 l/min	47.6 gpm
ROTATION TORQUE ¹⁾	2x 250cc	3212 Nm	2369 lb-ft
	2x 315cc	3692 Nm	2723 lb-ft
	2x 400cc	3654 Nm	2695 lb-ft
ROTATION PRESSURE MAXIMUM ^{1) 4)}		225 bar	3263 psi
ROTATION MOTOR MAXIMUM SPEED ²⁾	2x 250cc	162 rpm	
	2x 315cc	130 rpm	
	2x 400cc	102 rpm	

1) Intermittent value.

2) Continuous value. Maximum recommended speed 250 rpm.

3) Value for default OMS motors only.

4) Confirm the maximum pressure drop from the manual or the motor specifications.



BLT OPTION FOR BOLTING

BLT option modifies the flushing head of the rock drill. It has a short flushing head for bolting and general drilling. It can also be used for tunnelling and general excavations.

BLT option can be used with Doofor DF540L, DF550L, DF560L and DFR5 rock drills. It can also be used together with 2M option.

The BLT option requires special, shorter shank adapters. Short flushing head can use female R32 shank adapter.

BLT OPTION FOR DF540L

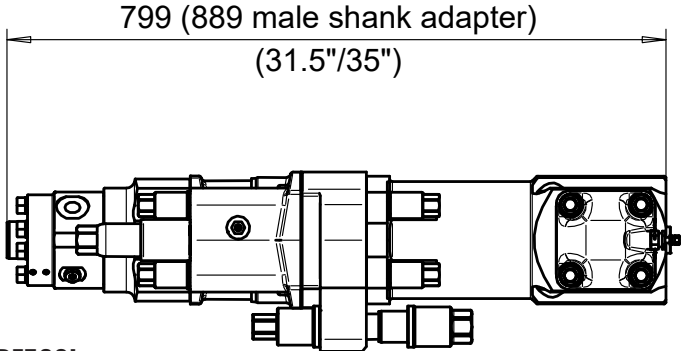

BLT OPTION FOR DF550L AND DF560L

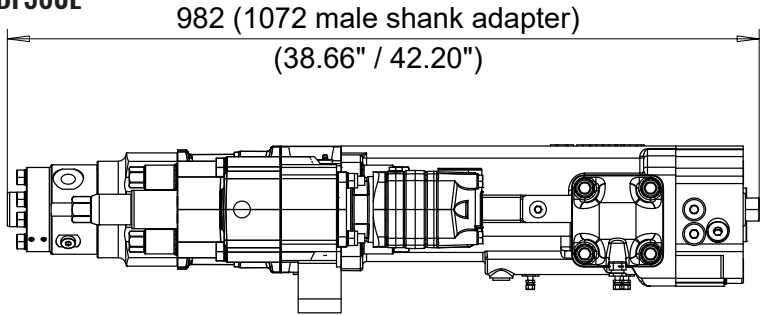

BLT OPTION FOR DFR5

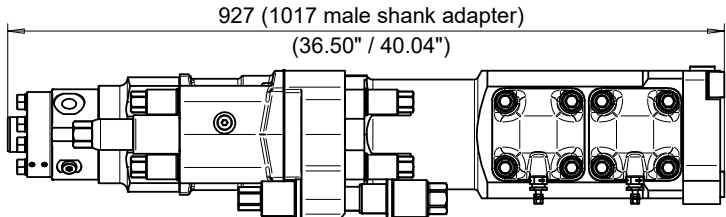

TECHNICAL SPECIFICATIONS

BLT OPTION SHANK ADAPTERS

BLT	Male R32, R38, T38 and female R32
-----	-----------------------------------

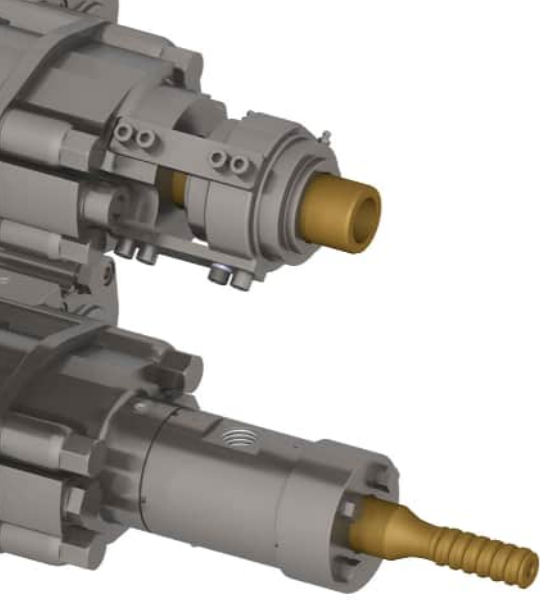

BLTG AND BLTF OPTIONS FOR GROUTING

BLTG has a long flushing head with extra seals and an option to use extra support bearing to protect the flushing seals. This option can also be used for tunnelling and general excavations.

The BLTG option requires special, longer shank adapters.

BLTF-option replaces the flushing head of the rock drill with a separate flushing box, making it possible to inject grouting material easily. It requires special female R38 shank adapters.

The BLTG and BLTF-options can be used with Doofor DF540L, DF550L, DF560L and DFR5 rock drills. They can also be used together with 2M-option

BLTG OPTION FOR DOOFOR DF540L

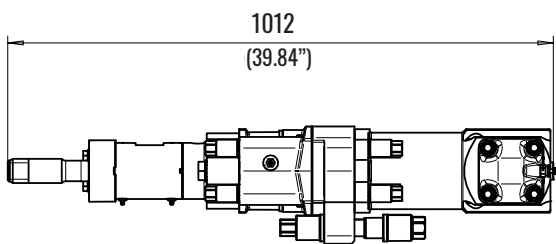

BLTF OPTION FOR DOOFOR DF540L

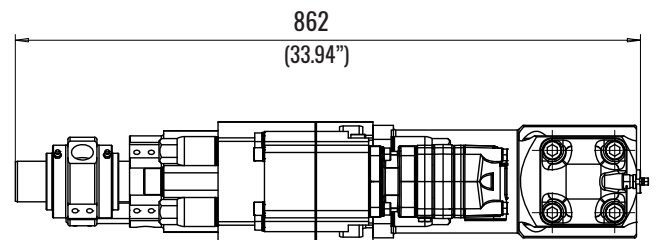

BLTG OPTION FOR DOOFOR DF550L AND DF560L

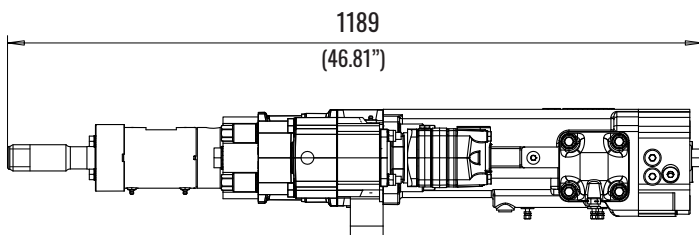

BLTF OPTION FOR DOOFOR DF550L AND DF560L

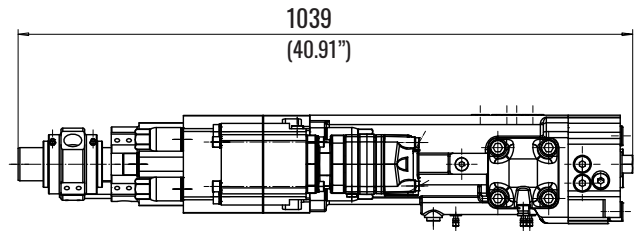

BLTG OPTION FOR DOOFOR DFR5

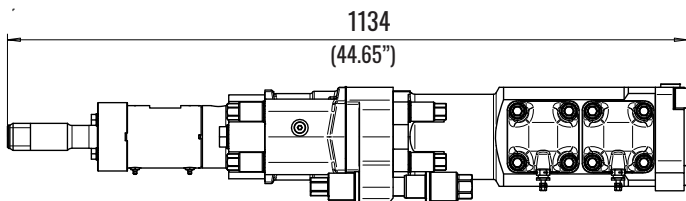

BLTF OPTION FOR DOOFOR DFR5

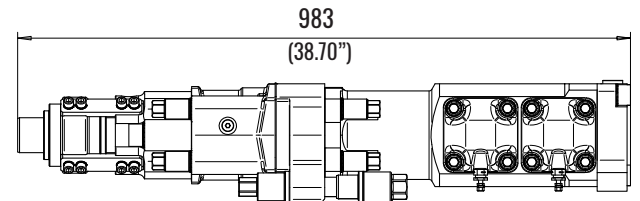

TECHNICAL SPECIFICATIONS

BLTG OPTION SHANK ADAPTERS

BLTG (LONG AND GROUTING VARIANTS)

Male R32, R38, T35, T38 and T45

BLTF OPTION SHANK ADAPTERS

BLTF

Female R32, T38, R38 and male T51.



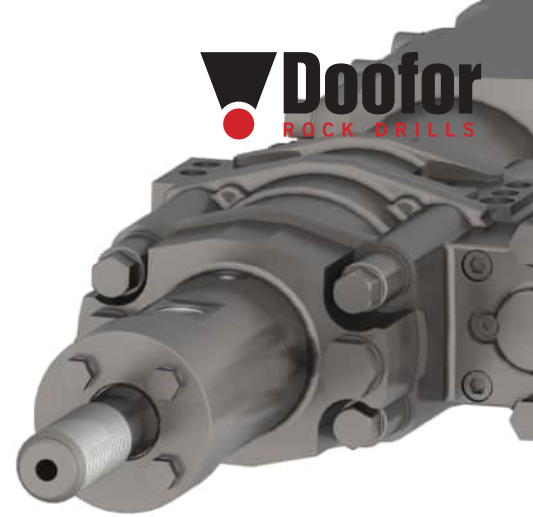

GRT GROUTING OPTION FOR DFR5 HYDRAULIC ROCK DRILL

GRT option for Doofor DFR5 allows the rock drill to be used in demanding grouting operations. With GRT option, the gear box is separated from the flushing device, which protects the gear box from harmful effects caused by leaking grouting fluid or water. GRT option also allow using grease to lubricate the flushing seals. Available in 19 kW and 21 kW versions. Performance specifications are similar to DFR5.

The product is protected by various patents.

**CIVIL ENGINEERING,
SURFACE AND UNDERGROUND**

DIMENSIONS

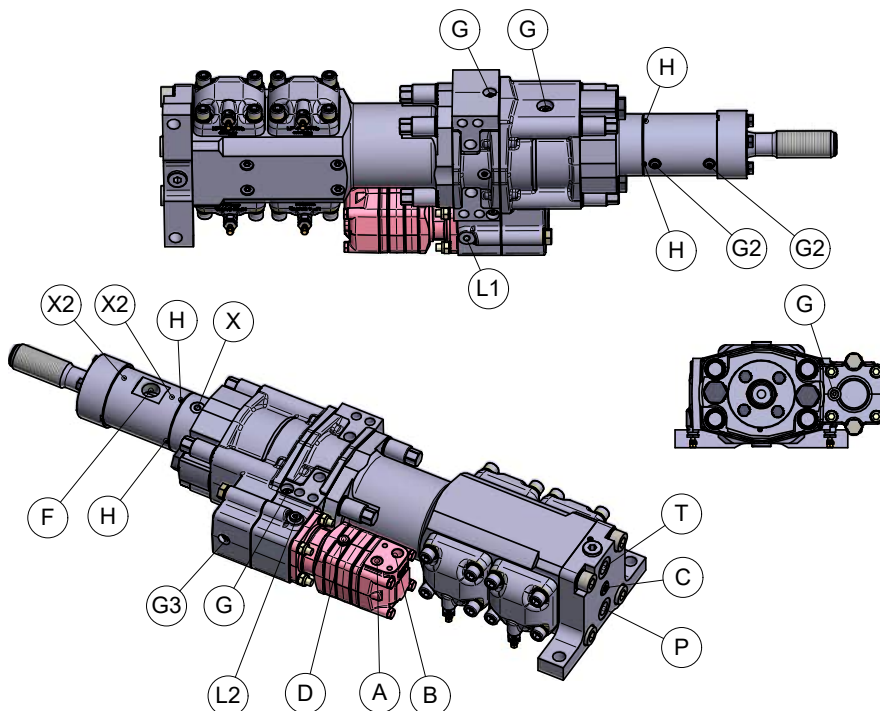
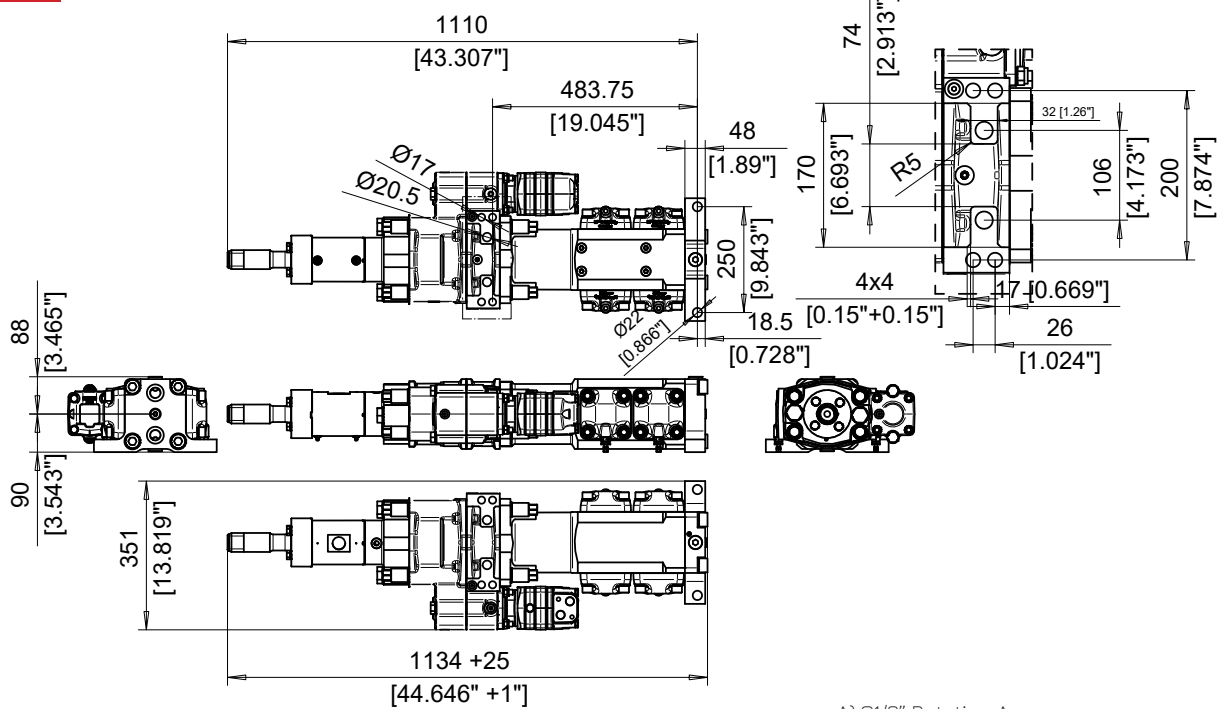

- A) G1/2" Rotation A.
- B) G1/2" Rotation B.
- C) G3/8" Breathing, connected with hydraulic hose to L1 or L2.
- D) G1/4" Motor drain. Connection not required.
- F) G1" Flushing inlet.
- H) Flushing leak indicator hole. Water or grout leaks from this hole when seals fail. Operation must then be stopped and the seals must be changed immediately.
- L1) G1/4" Pressurised air-oil mist lubrication inlet.
- L2) G1/4" Alternative pressurised air-oil mist inlet port.
- P) G3/4" Percussion pressure.
- T) G3/4" Percussion return to tank.
- X) G1/4" Lubrication exit. A short hose can be connected here to redirect the flow. Do not plug! Plugging will overheat the drill.

DOOFOR FEED SYSTEM COMPONENT KIT

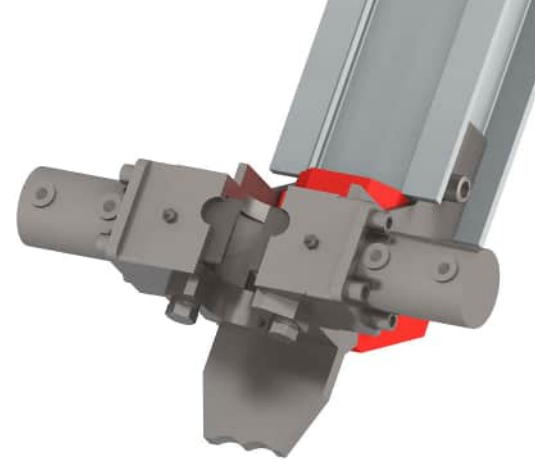

Doofor offers a set of supporting components for customers, who wish to build their own drill feed. For example, base machines for the drill feed can be excavators, mini-loaders and skid steer loaders. All components can be purchased separately.

Doofor feed system component kit is an excellent product for cutting down design and production costs.

Feed beam length is maximum 5500 mm and it can be cut to desired length. Typical practical length range for the feed beam is 2400 to 5500 mm.

Maximum feed depends on the choice of drill and options.

Maximum weight for the rock drill is 100 kg.

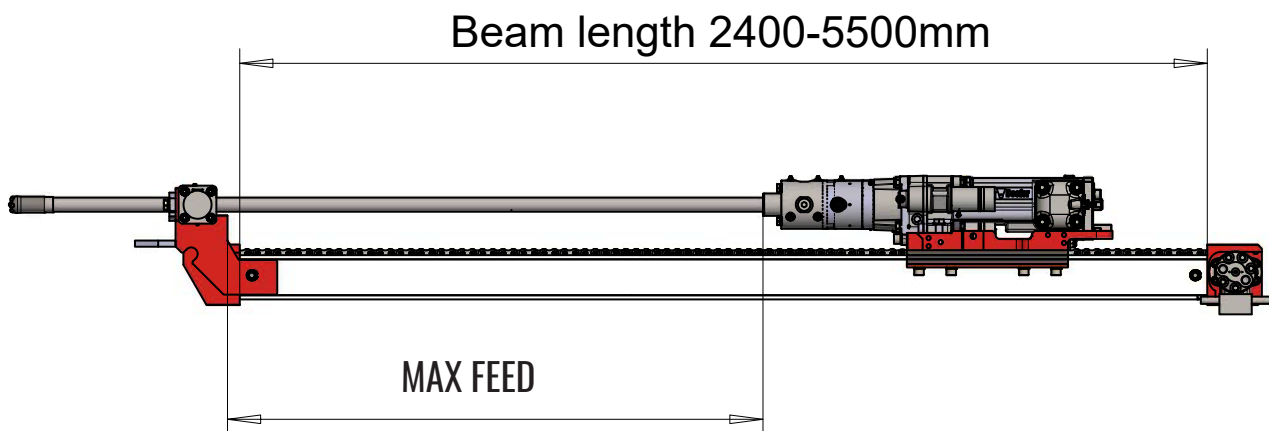

MAXIMUM DRILL ROD LENGTH EXAMPLES

DOOFOR DF538L	DRIFTER ROD	4700 mm (~4820 mm)
DOOFOR DF530S	DRIFTER ROD	4700 mm (~4850 mm)
DOOFOR DF530X	HEX 22 SHANK ROD	4000 mm (~4950mm)



DOOFOR FEED SYSTEM COMPONENT KIT

Robust machined carriage:

Durable machined carriage plates, with chain tensioning mechanism and wear-resistant slide plates.



Alternative option:

Manually openable or fixed guide in various sizes for your drilling needs.



Alternative option:

Hydraulic rod grabber with opposing cylinders.



Standard option:

Sturdy chain drive for feed. Motor with brake and counterbalance valve system.

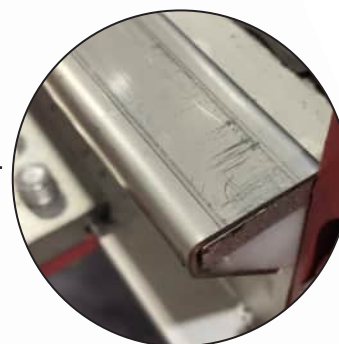

Alternative option:

Steel-plated sliding surfaces increase beam durability.



Extra options:

- Hose bracket
- Lubricator for the rock drill
- Hydraulic air compressor
- Hydraulic, pneumatic and manually operated drill steel retainers for hexagonal drill steels.

COATED SHANK ADAPTERS

Doofor offers coated shank adapters as an alternative for standard, uncoated shank adapter. Coated shank adapters come in variety of different sizes for variety of Doofor Hydraulic Rock drills.

Advanced, durable coating protects the shank adapter from the harmful effects of the corrosive flushing water and extends the usable drilling time for both the flushing seals and the shank adapter.

Combining coated shank adapters together with Doofor's effective drilling technology, easy, affordable and fast maintenance, and advanced options for Doofor rock drills, the drilling becomes cost-effective and sustainable.

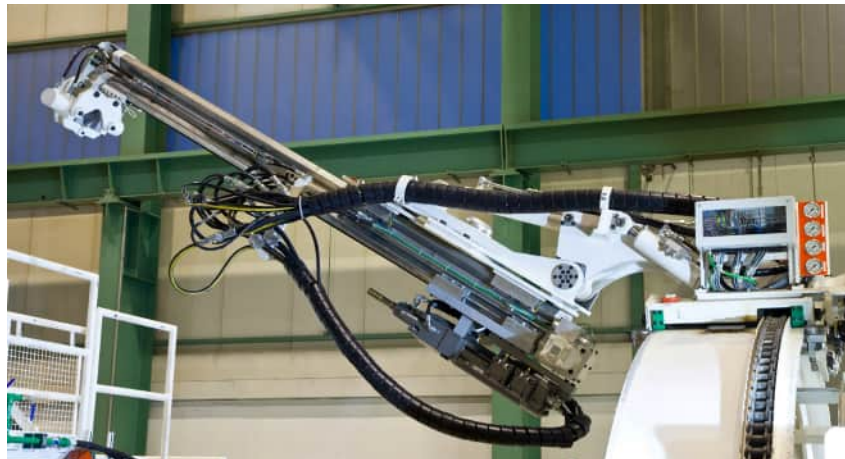

Doofor

ROCK DRILLS

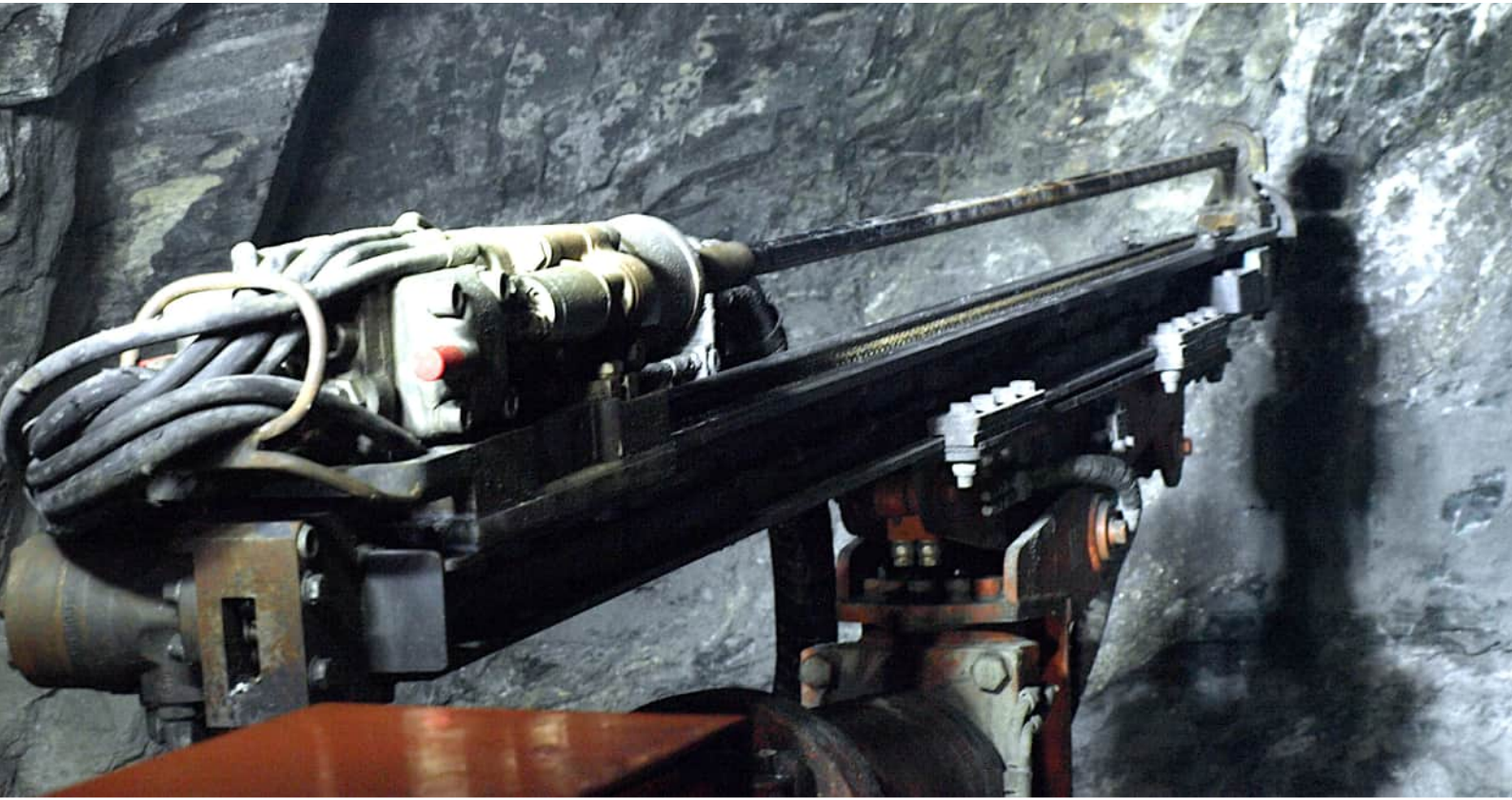



 **Doofor**
ROCK DRILLS
DOOFOR.COM

KAARNAKATU 11
FI-37150 NOKIA, **FINLAND**
TEL. +358 3 343 0747
INFORMATION@DOOFOR.FI

